



PATENTS FOR INVENTIONS

ABRIDGMENTS OF SPECIFICATIONS

CLASS 64 (iii)

SURFACE APPARATUS FOR
EFFECTING TRANSFER OF HEAT

[other than APPARATUS IN WHICH THE HEAT IS TRANSFERRED
FROM PRODUCTS OF COMBUSTION]

PERIOD—A.D. 1926-30 [244,801-340,200]



LONDON
PRINTED UNDER THE AUTHORITY OF HIS MAJESTY'S STATIONERY OFFICE
By the COURIER PRESS, BEDFORD STREET, LEAMINGTON SPA
PUBLISHED AT THE PATENT OFFICE, 25, SOUTHAMPTON BUILDINGS,
CHANCERY LANE, LONDON, W.C.2.

✓
608.3
G79

1932
Price 2s. 0d. [inland]; Postage abroad extra.



THE HISTORY OF THE
CITY OF BOSTON
FROM 1630 TO 1800
BY
JAMES OSGOOD
PUBLISHED BY
HARRIS AND BROTHERS
1856

*Crown copyright reserved. Permission to reproduce extracts must be obtained
from the Controller of H.M. Stationery Office.*



PATENTS FOR INVENTIONS

ABRIDGMENTS OF SPECIFICATIONS

CLASS 64 (iii)

SURFACE APPARATUS FOR EFFECTING TRANSFER OF HEAT

[other than APPARATUS IN WHICH THE HEAT IS TRANSFERRED
FROM PRODUCTS OF COMBUSTION]

PERIOD—A.D. 1926-30 [244,801—340,200]



LONDON
PRINTED UNDER THE AUTHORITY OF HIS MAJESTY'S STATIONERY OFFICE
By the COURIER PRESS, BEDFORD STREET, LEAMINGTON SPA
PUBLISHED AT THE PATENT OFFICE, 25, SOUTHAMPTON BUILDINGS,
CHANCERY LANE, LONDON, W.C.2.

1932.



EXPLANATORY NOTE

The contents of this Abridgment Class may be seen from its Subject-matter Index, which includes all index headings, subheadings, and subdivisions allotted to this Class, as well as cross-references under them, although there may be no cases affected within the period covered by this volume. For further information as to the classification of the subject-matter of inventions, reference should be made to the *Abridgment-Class and Index Key (Vol. I)*, published at the Patent Office, 25, Southampton Buildings, Chancery Lane, W.C.2, price 7s. 6d. (inland); 8s. 1d. (abroad).

It should be borne in mind that the abridgments are merely intended to serve as guides to the Specifications, which must themselves be consulted for the details of any particular invention. Printed Specifications may be purchased from the Patent Office at the uniform price of 1s. (inland); 1s. 0½d. (abroad).

NOTE.—The Patent Office does not guarantee the accuracy of its publications, or undertake any responsibility for errors or omissions or their consequences.



SUBJECT-MATTER INDEX



Surface apparatus for effecting transfer of heat between fluids in flow.

This heading includes only the construction of apparatus composed of several plates, tubes, and other elements presenting relatively large surfaces to the heating or cooling medium in comparison with the volume of the medium to be heated or cooled.

Adaptations and arrangements of surface-apparatus for special purposes are indexed only under separate headings, such as Cooling gases &c., [Class 29]; Distilling &c. liquids, [Class 32]; Heating water &c., [Class 64 (i)].

casings. 249,079. 251,755. 256,214. 260,941. 263,585. 273,803. 297,509. 309,106. 310,327. 328,718.

cleaning mechanically. *See* Pipes and tubes, Cleaning, [Class 99 (ii)].

coil-tube apparatus. *See* kinds &c. below.

concentric plate apparatus. *See* kinds &c. (plate apparatus) below.

distributing plates and partitions in fluid inlets and outlets. 256,594. 276,262. 297,509. 305,172.

drip-interception devices. *See* kinds &c. (straight-tube apparatus: misc.) below.

filling-pieces for tube-plate joints. *See* Pipes and tubes, Joints &c. for, [Class 99 (i)].

flat tubes, apparatus with. *See* kinds &c. (plate apparatus) below.

headers. 244,812. 247,500. 254,600. 256,185. 258,912. 258,984. 259,276. 263,649. 265,133. 265,201. 267,225. 268,093. 273,213. 284,413. 287,624. 290,812. 292,258. 292,343. 304,269. 305,172. 307,068. 309,106. 310,819. 311,574. 320,171. 332,065. 333,764. 334,127. 335,395. 338,685.

heat interchangers bodily removable from casing. *See* casings above.

incrustation and corrosion, preventing and removing. *See* Incrustation &c., Preventing &c., [Class 123 (i)].

kinds or types—

bowed tubes between headers. 248,999. 259,182. 260,357. 265,133. 305,172. 310,327.

coil-tube apparatus. 251,024. 251,424. 273,450. 301,426. 303,172. 314,433. 331,778. 334,333. 339,405.

Surface apparatus &c.—cont.

kinds or types—cont.

plate apparatus. 246,137. 246,231. 246,806. 247,086. 247,275. 247,935. 249,184. 250,169. 255,364. 255,711. 258,888. 259,824. 262,452. 265,597. 265,845. 271,461. 272,152. 273,306. 273,886. 276,013. 277,594. 278,704. 279,446. 281,819. 281,842. 285,151. 285,524. 286,757. 287,777. 289,661. 289,677. 289,698. 289,912. 290,868. 291,593. 293,759. 295,029. 295,106. 297,589. 297,643. 299,998. 301,426. 302,562. 304,183. 304,961. 307,191. 307,425. 310,411. 311,574. 312,702. 313,114. 313,140. 313,998. 316,699. 316,718. 319,099. 319,621. 320,279. 321,833. 323,499. 326,278. 326,381. 327,156. 327,377. 328,076. 329,714. 330,183. 330,590. 331,602. 331,982. 332,280. 338,097.

straight-tube apparatus—

concentric or jacketed tubes. 250,086. 250,792. 254,725. 260,066. 267,377. 270,250. 295,245. 302,167. 317,598. 327,398. 335,395. 337,027.

expansion and contraction of tubes, providing for, (*otherwise than* by expansion rings on casings). 248,712. 248,713. 249,079. 252,125. 273,605. 277,556. 307,068. 328,718.

Field-tube type. 244,859. 248,624. 250,792. 264,377. 271,567. 273,298.

honeycomb and like types, (tubular construction only). 247,935. 254,959. 270,891.

loop tubes, **L**-tubes, **U**-tubes, **W**-tubes, and serpentine tubes, (continuous lengths of tube having straight portions connected by bends). 247,500. 251,755. 252,133. 264,746. 270,148. 301,453. 307,068. 310,799. 312,470. 315,266. 322,366. 326,470. 330,385. 339,198.

miscellaneous—

drip-interception devices. 256,596. 271,065. 273,262. 306,243. 329,975.

tubes passing through helical baffles in cylindrical casing. 248,712. 308,715.

tube supports. 249,079. 254,702. 259,306. 289,715. 301,291. 306,243. 306,869. 310,327. 311,574. 315,865. 320,283.

rotary, reciprocating, and otherwise moving straight-tube apparatus. 249,534. 252,373. 313,780.



Surface apparatus &c.—cont.

kinds or types—*cont.*

straight-tube apparatus—*cont.*

straight tubes between headers or connecting-boxes.			
244,812.	246,593.	248,712.	
249,079.	249,534.	249,905.	249,906.
254,702.	256,215.	256,595.	256,596.
260,941.	263,585.	269,560.	273,125.
273,213.	273,803.	280,266.	280,649.
281,289.	282,717.	284,338.	284,413.
294,836.	297,509.	299,085.	309,543.
304,269.	305,172.	307,068.	307,854.
308,715.	309,445.	315,865.	316,918.
319,628.	328,718.	331,910.	333,764.
336,355.	336,755.	339,869.	339,870.
339,925.			

tubes closed at one end and connected at other end to header, (*other than Field tubes*). 308,966.

trough and open-channel apparatus. 254,100.
longitudinal baffles, arrangements of. 254,626.
263,585. 276,262. 284,338. 299,085. 333,764.
336,355. 337,631.

making and treating by operations of interest apart from product. *See separate headings, such as Electrolysis &c., [Class 41]; Metals, Bending &c., [Class 83 (iv)].*

materials for making. 267,377. 275,188.
292,484. 294,687. 299,100. 310,880. 311,092.
326,981. 338,818.

miscellaneous—

blocks traversed by sets of fluid passages. 285,151.

special materials for making. 307,843.

tube-filled tubes. 304,728.

two series of tubes or passages formed in plates or blocks. 263,818. 338,818.

Surface apparatus &c.—cont.

nozzles, flared inlets, and like devices on tubes for facilitating or restricting flow of fluid. 248,713. 258,912. 261,731. 274,629. 279,526. 294,518. 296,605. 322,280.

pipes and tubes, joints and couplings for. *See Pipes and tubes, Joints &c. for, [Class 99 (i)].*

plate apparatus. *See kinds &c. above.*

straight-tube apparatus. *See kinds &c. above.*

stuffing-boxes and substitutes therefor. *See Stuffing-boxes &c., [Class 122 (v)].*

trough and open-channel apparatus. *See kinds &c. above.*

tube-plates. 273,605. 297,509. 305,172. 309,106. 311,245. 322,280. 328,718.

tubes, cross-sections of, (*including gills for tubes*). 256,579. 256,693. 260,357. 260,759. 269,851. 270,609. 271,122. 272,852. 279,245. 281,289. 284,338. 286,682. 287,777. 289,320. 289,912. 290,471. 292,041. 292,507. 294,687. 295,029. 299,892. 304,272. 304,981. 307,191. 309,798. 309,845. 311,092. 313,140. 321,820. 325,249. 325,742. 327,398. 330,590. 331,392. 332,455. 332,838. 337,236. 339,835.

flat tubes. *See kinds &c. (plate apparatus) above.*

tubes having internal baffles, partitions, and like fittings. 247,275. 250,792. 260,066. 280,683. 286,757. 311,092. 317,598. 319,626. 330,590. 331,602.

tubes, securing to tube-plates and the like. *See Pipes and tubes, Joints &c. for, [Class 99 (i)].*

NAME INDEX

The names in *italics* are those of persons by whom inventions have been communicated to the applicants for Letters Patent.

- Akt.-Ges. Brown, Boveri, et Cie. 300,543. 301,291 310,327
- Akt.-Ges. der Maschinenfabriken Escher, Wyss, et Cie. 273,262
- Aktiebolaget Ljungströms Angturbin. 295,029
- Aktiebolaget Svenska Järnvagsverkstäderna. 301,426
- Allan, J. 319,628
- Allgemeine Elektrizitäts Ges.* 271,065. 337,631
- Allott, G. W. 251,755
- Amme, Giesecke, & Konegen Akt.-Ges. 246,806
- Anciens Etablissements M. P. Velut. 304,728
- Andale Engineering Co.* 273,213
- Anderson, J. 254,600 332,065
- Armocost, W. H. 286,682
- Associated Electrical Industries, Ltd. 334,127
- Babcock & Wilcox Co.* 264,746 276,262. 320,283. 326,470
- Babcock & Wilcox, Ltd. 264,746 276,262. 320,283. 326,470 339,925.
- Beck, E. F. A. D. 304,272
- Bergedorfer Eisenwerk Akt.-Ges. 335,395
- Berlin, D. W. 290,868
- Bierens, R. 334,127
- Billetop, T. C. 319,626
- Birmingham Aluminium Casting (1930) Co., Ltd. 326,278
- Blanchard, W. J. 322,280
- Boer, F. de. 319,621
- Borns, R. E. G. 339,835
- Boveri, et Cie, Akt.-Ges. Brown. *See* Akt.-Ges.
- Bowerbank, J. W. 247,086
- Bramwell, F. H. 248,999
- British Electric Transformer Co., Ltd. 327,398
- British Thomson-Houston Co., Ltd. 265,201. 273,803 287,624. 302,167. 311,574
- Brown, Boveri, et Cie, Akt.-Ges. *See* Akt.-Ges.
- Browne-Cave. *See* Cave.
- Büchner, W. 289,320
- Bull, A. W. H. 258,984
- Bundy, H. W. 292,507
- Burdick, C. L. 261,731
- Burrow, W. C. 325,249
- Burstall, A. F. 279,526
- Carey, W. F. 279,256
- Carrier Engineering Co., Ltd. 309,845
- Casale-Sacchi. *See* Sacchi.
- Cave, T. R. Cave-Browne-. 299,085
- C.B.A. Radiator & Engineering Co., Ltd. 339,835
- Challe, B.* 293,759
- Chambers, & Co., Ltd., Newton. *See* Newton.
- Chausson, Soc. Anon. des Usines. *See* Soc. Anon.
- Chavanne, L. 249,534
- Chavara, M. 287,777
- Chew, J. S. 260,759
- Churruca, I. 287,777
- Compagnie des Surchauffeurs.* 308,966. 310,799. 312,470 316,918.
- Compagnie Nationale des Radiateurs.* 250,169
- Coventry Motor Fittings Co., Ltd. 321,820
- Coventry Radiator & Presswork Co., Ltd. 304,981
- Crane Packing Co. 248,713
- Crane Packing, Ltd. ... 294,518
- Crittall, R. G. 270,148
- Cross, R. C. 321,833
- Dairy Accessories Co., Ltd. 319,099
- Daniell, B. 281,842
- „ E. 281,842
- Daniels, G. W. 251,024
- Davy, C. H. 339,925
- Dehn, F. B. 259,824. 265,845 322,366
- Delas, Soc. des Condenseurs. *See* Soc.
- Delaunay-Belleville, Soc. Anon. des Etablissements. *See* Soc. Anon.
- Derry, G. C.* 254,702. 269,560 315,865
- Desson, G. 326,981
- Desson et Cie, Etablissements G. *See* Etablissements.
- Dexter, W. A. 254,626
- Donaldson, T. 273,605
- Dumas, R. ... 287,624. 311,574
- Electrolux, Ltd. 275,188 334,333
- Elson, J. A. 254,100
- English Electric Co., Ltd. 259,306
- English, W. E. 271,567
- Ernst, A. F.* 278,704
- Escher, Wyss, et Cie, Akt.-Ges. der Maschinenfabriken. *See* Akt.-Ges.
- Etablissements G. Desson et Cie. 326,981
- Evennett, F. C. F. ... 289,715
- Fairey, C. R. 246,231
- Ferranti, Ltd. 299,998. 323,499
- Ferranti, S. Z. de. 299,998 323,499
- Fiat Soc. Anon. 330,183
- Findlay, W. St. John's-. 280,266
- Föge, H.* 302,562. 332,280



ULTIMHEAT®
VIRTUAL MUSEUM

Forgan-Potts. <i>See</i> Potts.	Karmazin, J. 270,609. 290,471	Muller, H. 309,798
Fothergill, H. 244,812. 249,905 249,906. 306,243	Kearsley, G. W. 268,093	Müller, P. H. 273,125
Fraser, K. 274,629	Kent, S. N. 319,626	Munday, R. L. 255,711
Froude, Ltd., Heenan & <i>See</i> Heenan.	Kirgan, J. F. 260,941	Musgrave, J. L. 270,148
Fuchs, A. 262,452	Kochs & Co., Ltd., W. E. 302,562. 309,798. 332,280	Napier, A. L. 306,869
Gallay, Soc. Anon. des Usines J. <i>See</i> Soc. Anon.	Konegen Akt.-Ges., Amme, Giesecke, & <i>See</i> Amme.	Nelson, E. H. 252,125
Garratt, L. 321,820	Kranzlein, G. 305,172. 309,445 331,910	Newton, Chambers, & Co., Ltd. 251,755
Gibbs, H. 249,184	Kuhlerfabrik Langerer & Reich Akt.-Ges. ... 304,183. 311,140	Nichols, E. B. 265,133
„ T. H. 249,184	Lafeuille, F. 301,453	Nielsen, N. J. 307,854. 337,027
Giesecke, & Konegen Akt.-Ges., Amme. <i>See</i> Amme.	La Mont Corporation. 278,704	Norddeutsche Kùhlerfabrik Akt.-Ges. 258,888
Griscom-Russell Co. ... 248,712 249,079. 252,125. 256,579 259,182. 308,715.	La Mont, W. D. 278,704	Owen, W. H. 309,845. 312,702 313,114. 330,590
Guggenheim Bros. 261,731	Lande, B. L. M. van der. 338,685	Pais, A. 263,818
Hadamovsky, P. 265,597	Langerer & Reich Akt.-Ges., Kuhlerfabrik. <i>See</i> Kuhler- fabrik.	„ C. 263,818
Hagstedt, C. N. G. 250,792	Leek, A. E. 270,250	Parkinson, A. 260,759
Hannan, J. R. 271,567	Leveque, P. 281,289. 293,759	Parsons, Sir C. A. 258,912 292,258
Harlow, W. F. 328,076	Levron, M. 246,137	Payne, F. E. 248,713
Harris, T. H. 256,693	Liotard Frères, Soc. Anon. des Anciens Etablissements. <i>See</i> Soc. Anon.	Payne, M. 331,392
Harrison, J. M. 331,982	Liverpool Refrigeration Co., Ltd. 319,628	Petty, T. 329,975
Hartmann, M. & E. ... 271,461	Lloyd, H. J. 280,683	Pfaudler Co. 265,133
Hartmann, P. E. 271,461	Lobelle, M. 246,231	Platen - Munters Refrigerating System Aktiebolag. 275,188
Hatfield, H. S. 281,819	Lucke, C. E. 256,214. 256,215 256,594. 256,595. 256,596	Popescu, T. 263,818
Heenan, J. N. D. 246,593 294,687	Lùtschen, E. 255,364	Potts, C. H. 285,524
Heenan & Froude, Ltd. 320,279 331,602	McNeil, C. 313,780	Potts, J. Forgan. 260,357
Heizmann, J. 297,643	Macpherson, M. C. 291,593	Power-Gas Corporation, Ltd. 294,836
Hepworth, F. 307,191. 328,718	Mannesmannröhren - Werke. 256,185	Price, J. 248,712. 249,079 259,182
Higgins, C. F. 263,585	Marks, E. C. R. 311,092	Priser, D. F. 250,086
Hillier, H. 273,450	Martin, E. A. 319,099	Pritchard, P. 326,278
Houston Co., Ltd., British Thomson-. <i>See</i> British.	„ F. G. 299,100	Purchase, S. N. 320,171
Howden & Co., Ltd., J. 295,106 316,718. 327,156. 336,755	„ N. 280,649	Purslow, H. 254,600. 332,065
Hubert, C. A. 337,236	Maschinenfabrik Ing. H. Sim- mon. 252,373	Quiggin, D. A. 309,106
Hughes, A. E. 296,605	Mather, C. 325,742	Rambush, N. E. 294,836
Hume, J. H. 295,106. 316,718 327,156. 336,755	„ J. W. 259,306	Ramsay, W. 299,100
I.G. Farbenindustrie Akt.-Ges. 307,843	Matzka, W. 267,377	Rand Co., Ingersoll-. <i>See</i> Ingersoll.
I.G. Farbenindustrie Akt.-Ges. 338,818	Menzel Akt.-Ges. 289,677	Randle, F. 263,649
Ingersoll-Rand Co. ... 260,941	Menzel, E. 289,677	Reich Akt.-Ges., Kuhlerfabrik Langerer & <i>See</i> Kuhlerfabrik.
International General Electric Co., Inc. ... 271,065. 337,631	Metropolitan-Vickers Electrical Co., Ltd. 273,886	Ris, K. B. 308,715
Jackson, L. H. 304,981	Miles, T. V. 241,755	Robinson, P. 244,859. 248,624 339,869. 339,870
Jacobi Akt.-Ges. 259,824 265,845	Millard, R. B. 259,276	Robson, S. 297,509
Johannsson, P. 331,778	Millington, W. E. W. 267,225	Roper, H. J. 251,424
Johnsen, E. A. 290,812	Mirrlees Watson Co., Ltd. 254,626	Royal Baking Powder Co. 311,092
Johnson, J. Y. 338,818	Montey, H. G. 254,100	Royle, A. G. 295,245
Jones, R. C. 256,579	Morgan, G. U. 264,377	Royles, Ltd. 267,377. 295,245
Junkers, H. 332,455	Morra, M. 289,698	Russell Co., Griscom-. <i>See</i> Griscom.
	Mort, J. 247,500	
	Mortrud, E. 273,298	
	Morton & Co., Ltd., R. 244,859 248,624. 339,869. 339,870	
	Muchka, J. 272,152	



Sacchi, M. Casale. 289,661	Soc. of Chemical Industry in Basle. 338,097	Underfeed Stoker Co., 328,076
Sadler, J. H. 279,245	Southwestern Engineering Corporation. 259,276	Upton, H. E. 320,171
" P. T. 279,245	Stancliffe, C. W. 285,151	
St. George's Engineers, Ltd. 254,600. 332,065	286,757. 289,912	
St. John's-Findlay. <i>See</i> Findlay.	Stassano, H. 254,725	Velut, Anciens Etablissements M. P. <i>See</i> Anciens.
Salerni, E. M. 247,275	Stead Tube Co., Ltd., Talbot. <i>See</i> Talbot.	Vergés, R. C. 254,959
Samesreuther, R. 273,306	Stenfors, F. I. E. 329,714	Vickers Electrical Co., Ltd., Metropolitan. <i>See</i> Metropolitan
276,013. 292,484. 305,172	Stephens, H. O. 265,201	
Samesreuther & Co., Ges. 309,445. 331,910	Still, W. J. 271,122	
Samuelson, F. 273,803	Storoni, E. 260,066	
Sankey & Sons, Ltd., J. 280,649	Sturtevant Co., B. F. 254,702	Wade, H. 304,269
Schmidt'sche Heissdampf-Ges. 303,172. 307,068. 339,405	269,560. 315,865. 325,249	Wagner, C. O. 333,764
Seligman, R. 297,589. 307,425	Sugden, T. 292,343	Walker, G. H. 320,279. 331,602
310,411. 327,377	Superheater Co. 286,682	Walton, J. N. 248,713
Serck, O. 270,891	Superheater Co. 330,385	Ware, H. M. 321,833
Serck Radiators, Ltd. 270,891	339,198	Watson Co., Ltd., Mirrlees. <i>See</i> Mirrlees.
277,556. 307,191. 320,171	Superheater Co., Ltd. 308,966	Wheeler Condenser & Engineering Co. 249,905. 249,906
333,764.	310,799. 312,470. 316,918	White, A. E. 273,213
Shaw, J. C. 317,598	330,385. 339,198.	" W. A. 313,998. 326,381
Silica Gel Corporation. 304,269	Synthetic Ammonia & Nitrates, Ltd. 248,999. 279,526	Whitlock Coil Pipe Co. 322,366
Simmen, O. 282,717		Wilcox, Ltd., Babcock & <i>See</i> Babcock.
Simmon, Maschinenfabrik Ing. H. <i>See</i> Maschinenfabrik.	Talbot-Stead Tube Co., Ltd. 332,838	Wilkinson, F. C. W. 294,518
Skóda Works, Plzen. ... 310,819	Talbot, W. J. 332,838	Windhoff, J. A. P. ... 277,594
Slade, R. E. 279,526	Thompson, J. L. 327,398	Worthington Pump & Machinery Corporation. ... 256,214
Smith, A. R. 302,167	Thompson Water Tube Boilers, Ltd., J. 306,869	256,215. 256,594. 256,595
Soc. Anon. des Anciens Etablissements Liotard Frères. 314,433. 315,266.	Thomson-Houston Co., Ltd., British. <i>See</i> British.	Wyndham, J. N. 316,699
Soc. Anon. des Etablissements Delaunay-Belleville. 252,133	Thornycroft, Sir J. E. 273,605	" S. L. 316,699
284,338.	Thornycroft & Co., Ltd., J. I. 273,605	Wyss, et Cie, Akt.-Ges. der Maschinenfabriken Escher. <i>See</i> Akt.-Ges.
Soc. Anon. des Usines Chausson. 247,935	Tindale, H. 284,413	
Soc. Anon. des Usines J. Gallay. 292,041. 299,892	Todd, U. G. 265,133	
304,961.	Tomkins, F. E. 268,093	
Soc. des Condenseurs Delas. 336,355	Torre, E. 311,245	Yorkshire Copper Works, Ltd. 274,629
Soc. La Précision Moderne. 279,446	Trane, R. N. 269,851. 272,852	Young, J. W. 273,886
	Trent Process Corporation. 310,880	
	Trent, W. E. 310,880	
	Turner, J. ... 299,998. 323,499	Zimmermann & Co. ... 277,556



ULTIMHEAT®
VIRTUAL MUSEUM

Table with multiple columns containing names and numbers, likely a list of items or a directory. The text is faint and difficult to read.

CLASS 64(iii)

SURFACE APPARATUS FOR EFFECTING TRANSFER OF HEAT

[other than APPARATUS IN WHICH THE HEAT IS TRANSFERRED FROM PRODUCTS OF COMBUSTION]

Patents have been granted in all cases, unless otherwise stated. Drawings accompany the Specification where the abridgment is illustrated, and also where the words *Drawings to Specification* follow the date.

244,812. Fothergill, H. May 29, 1925.

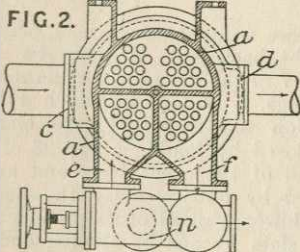
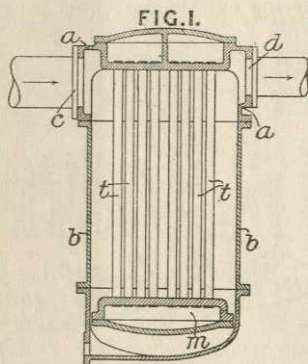

Straight tubes between headers; headers. — A heater or cooler comprises a shell *b*, carried by one header *a*, enclosing the tubes *t* and the other header *m*, the header *a* having its tube plate, the water inlet and outlet pipe connections *e*, *f*, the partitions separating the open ends of the groups

of tubes, and the connections *c*, *d* or inlet and outlet of the heating medium constructed integrally in one casting. A valve chest *n* for controlling the supply of water to the heater may be fitted to the upper header, comprising a bye-pass

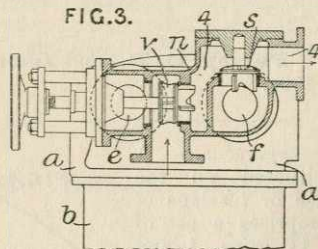

valve *v* with alternative seats admitting water either to the tubes or to a passage *4*, Fig. 3. A valve *S* is lifted by the passage of water through the tubes but closes when water is being by-passed.

244,859. Morton & Co., Ltd., R., and Robinson, P. Oct. 16, 1924.

Field-tube apparatus. — In a water heater in which steam is passed through tubes in the water, the headers and connected parts are arranged to permit easy detachability. The container *10* is of rectangular form, with external ribs *11* to support

ing material, and a wooden covering 13. One of the sides is detachable, or may be hinged. A number of tubular headers 25 are each formed

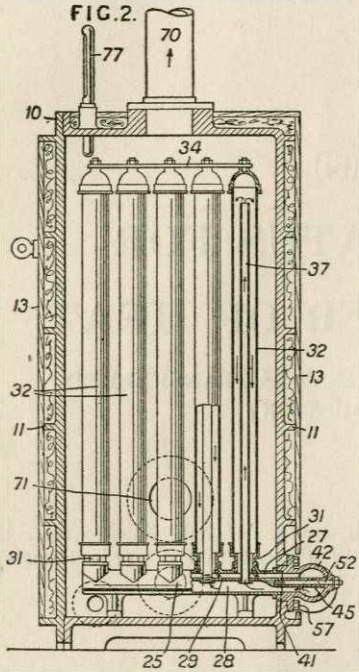

with upper and lower passages 27, 28, and tubes 32 are mounted on the upper sides of the headers by connecting members 31. The tubes 32 are

closed at their upper ends, which are secured to a bar 34, and each contains an inner tube 37 secured to the dividing plate 29 of the header. One end of the header is closed, and the other end is adapted to be secured against the face 41 of a transverse supply and discharge conduit 42 by means of a bolt 52. The conduit 42 is divided by a partition 45 into two passages, for supply and discharge of steam, the partition being thickened to receive the securing bolt 52. The conduit 42 is secured by studs and nuts 57. Each of the headers, with its heating pipes, can be removed as a unit.

246,137. Levron, M. Jan. 19, 1925, [Convention date].

Plate apparatus.—Adjacent passage-ways *a, b, c* for air &c. to be heated and for the heating medium are formed by plates 1 - 4 secured at their edges by means of channel members 5, U-shaped strips 6, or end-plates with grooves, all slidable endwise to grip the adjacent edges of the plates and members 5 in the manner of a dove-tail.

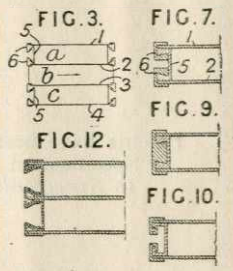

Examples illustrating ways of carrying out the invention are shown in the Figures.

246,231. Fairey, C. R., and Lobelle, M. Nov. 1, 1924.

Plate apparatus.—A radiator situated on the wing surface or fuselage of aircraft comprises a set of flat tubes 11, Figs. 1 and 3, extending side-by-side in the general direction of the wind stream and connected to front and rear headers, the inner or rear edges of the tubes being united to a back plate 20, which is preferably corrugated transversely or obliquely. The plate 20 is united to the back edges of the tubes as by soldering at the points 21, and the corrugations provide passages for air at the backs of the tubes. The ends of the tubes are enlarged to form abutting rectangular mouths 14, which are soldered to-

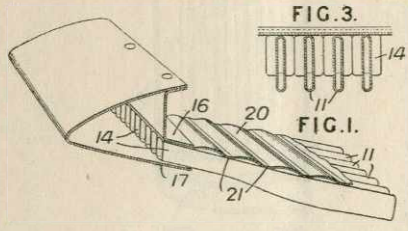
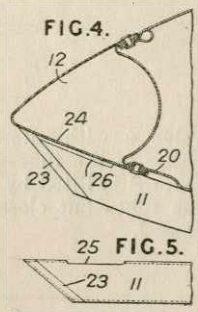

gether and are secured as a whole, with the flat margin of the back plate 20, between out-turned flanges 16, 17 of the header. In the modification shown in Figs. 4 and 5, in which tubes 11 of wedge section are employed, the ends of the tubes are closed by folding a flap 23 of one face over the end of the other face, and an opening 25 is formed by cutting away the back of the tube. The lower wall 24 of the header 12 is provided with slots formed by slitting and pressing out flanges 26, and the tubes are secured to the wall by soldering the flanges 26 around the tube openings 25.



246,593. Heenan, J. N. D. Nov. 1, 1924.

Straight tubes between headers.—A heat-exchanger incorporated in a turbine structure between the rotor 16 and the stator 18, Fig. 6, comprises cylindrical headers 19, 20 supplied with a heat-carrying medium such as oil from a duct 22 and connected by radial tubes 21 fitted with radiating fins. The tubes 21 may be arranged parallel to one another, Fig. 7. Hydrogen or mercury may be used instead of oil.

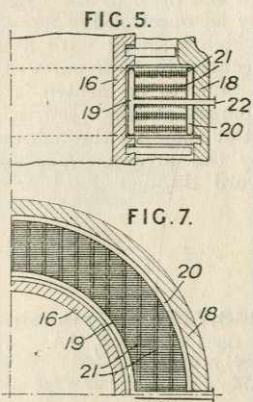

246,806. Amme, Giesecke, & Hentgen Akt.-Ges. Jan. 28, 1925, [Convention date].

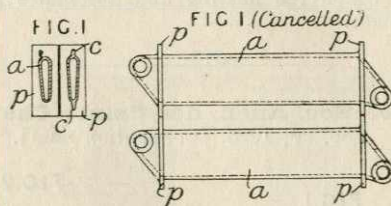

Plate apparatus.—A heating element, particularly described as for use in drying grain, comprises a hollow body *a*, extending horizontally and provided with external end plates *p* adapted to fit together to form a continuous wall. The of the casing. A plurality of the casings *e*¹ may be provided with top and bottom longitudinal ribs *c*.

The Specification, as open to inspection under Sect. 91 (3) (a) comprises also elements of oval cross section. This subject-matter does not appear in the Specification as accepted.

247,086. Bowerbank, J. W. July 22, 1925.

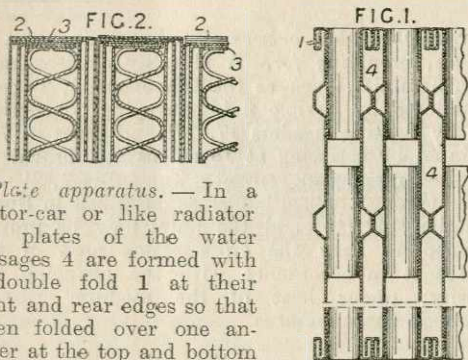
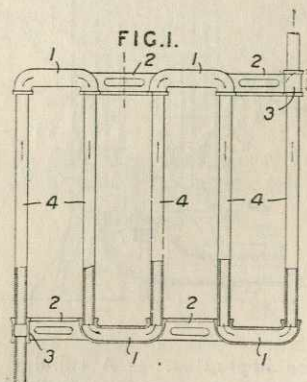

Plate apparatus.—In a motor-car or like radiator the plates of the water passages 4 are formed with a double fold 1 at their front and rear edges so that when folded over one another at the top and bottom of the radiator block, six thicknesses 2, 3 of metal are juxtaposed.

in a tortuous path around removable baffles in a casing, the casing *e*¹ is made of elongated section, the baffles *e*² extending from top to bottom of the casing. A plurality of the casings *e*¹ may be mounted in an outer casing *e* containing cooling medium. The baffles are preferably of L-section and so connected together as by rods *e*³ that they may be removed simultaneously. Specifications 224,568, [Class 51 (ii), Furnaces and kilns for applying &c.], and 247,274, [Class 8 (ii), Air and gases, Treating &c.], are referred to.

247,500. Mort, J. Nov. 12, 1925.



Serpentine-tube apparatus.—A heating worm or coil comprises two members each having a number of hollow elbows 1 joined by cross-pieces 2,

247,275. Salerni, E. M. Nov. 10, 1924.

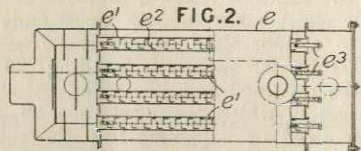
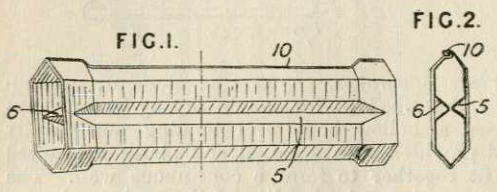

Plate apparatus; straight tubes with internal baffles.—In condensers of the type in which the medium undergoing treatment is caused to flow

and a sleeve 3 which may be straight or bent and is secured by a cross-piece to the last elbow. Two of these members are joined by straight tubes 4 through which the heating fluid circulates in a zig-zag path.

247,935. Soc. Anon. des Usines Chausson. Feb. 20, 1925, [Convention date].



Honeycomb-tube apparatus, for use with internal-combustion engines, are made from tubes, each of which has a pair of internal longitudinal ribs 5, 6 arranged opposite to one another and in contact under external pressure, the ribs tapering at their ends into the end portion of the tube. The tubes are made by stamping from a sheet of metal folded and the edges joined as at 10.

The Specification, as open to inspection under Sect. 91 (3) (a) comprises also the provision of more pairs of ribs in a tube. This subject-matter does not appear in the Specification as accepted.

248,624. Morton & Co., Ltd., R., and Robinson, P. July 16, 1925.

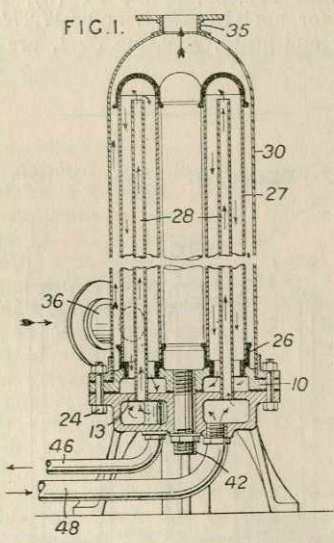

Field-tube apparatus. — A tubular heater for liquids by means of steam or other fluid comprises a horizontal header 10 divided into two compartments by a horizontal partition 13 formed on the lower portion, which is separate from the upper portion. The upper portion is formed

with openings which receive connecting members 26 carrying heating tubes 27 formed of copper and closed at the top. Each tube 27 is provided with an inner tube 28 secured to the partition 13 and open at the top. The tubes are enclosed by an outer casing 30 of thin metal, e.g. copper, which is fitted with a flange at the bottom and secured to both parts of the header by bolts 24. Liquid to be heated is admitted at 36 and discharged at 35. Steam is admitted and discharged at 46, passing through the heating tubes as shown by the arrows. A drain tube 42 passes downward through the header.

248,712. Griscom-Russell Co., (Assignees of Price, J.). March 3, 1925, [Convention date].

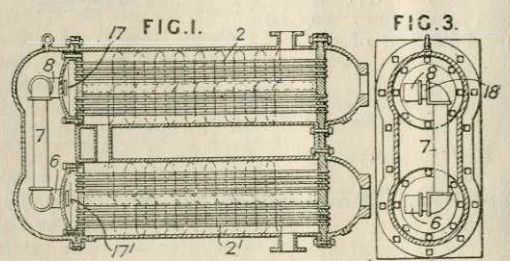

Straight tubes between headers; expansion of tubes, providing for.—A plurality of heat-transferring units, such as the tube-nests 2, 2' communicate by flexible fluid-conveying connections as by floating headers 17, 17' and pipes 6, 7, 8 jointed by screwing at 18 so as to provide a limited rocking movement. The tubes 2, 2' may pass through helical baffles as described in Specification 142,715, and the units may be proportioned to vary the cross-section area of the passages in accordance with the changing viscosity, under heat of the medium passing through the apparatus.

248,713. Crane Packing Co., (Assignees of Payne, F. E., and Walton, J. N.). March 9, 1926, [Convention date]. Void [Published under Sect. 91 of the Acts].

Expansion of tubes, providing for; nozzles on tubes.—To facilitate renewal of condenser tubes renewable short tubes 16 with flared ends 17 are secured to a tube-plate 10 and the free end of the long tube 22 slides in packing 20 forced against the inturned end 19. Fig. 4 shows a modification in which the short tube 29 is but a ferrule screwed or expanded into the tube-plate 10, while Fig. 5 shows another form of short tube 33 having in addition to a flared end a filling-piece 35 to present a smooth curved surface to the inflowing liquid.

(For Figures see next page.)

248,713.

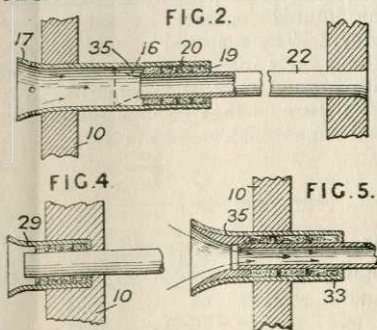

plurality of thermally insulating cylindrical baffles C, D forming annular spaces 1 - 5, containing a large number of small cross-section tubes 6 extending parallel to the axis of the

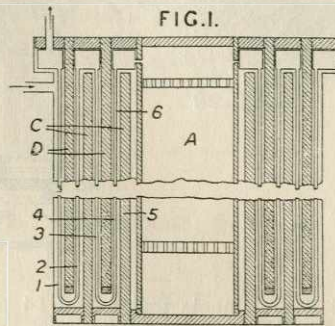

248,999. **Synthetic Ammonia & Nitrates, Ltd., and Bramwell, F. H.**
July 22, 1925.

Bowed tubes between headers.—In a process for example for carrying out the synthesis of ammonia a heat exchanger is used comprising a

apparatus up and down within the annuli and connected so that the gas flows through them in parallel. A central catalyst-space A is provided. Specification 229,354, [Class 1 (i), Chemical processes &c.], is referred to.

249,079. **Griscom-Russell Co.,** (Assignees of Price, J.). March 13, 1925, [Convention date].

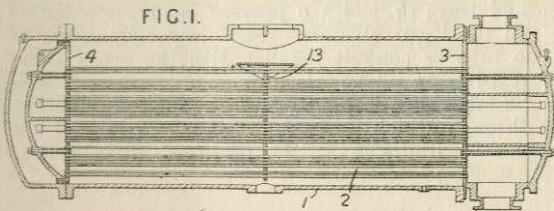

Straight tubes between headers; expansion of tubes, providing for; tube supports.—The tubes 2 of a heat-exchanger are supported between the tube-plates 3, 4 by a plate 13 detachably secured to the casing as by bolts 14 in such a manner that the heat-exchanging element may be removed from the casing 1 as a unit. By securing the bolts 14 within a sleeve 17 of larger diameter, a limited variation in position of the support is provided for. Angle-iron stays 27 extend between the tube-plate 3 and the support

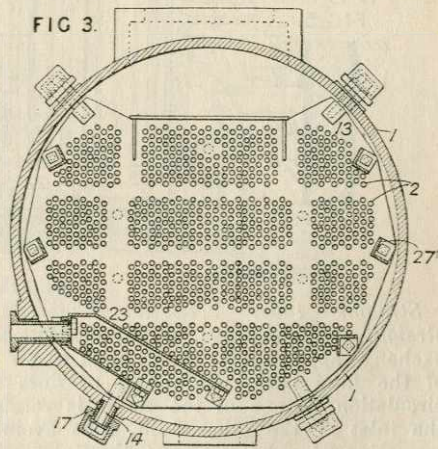

13. If a baffle 23 is provided over the air outlet, it is so attached as to be removed with the tube unit.

249,184. **Gibbs, H., and Gibbs, T. H.**
June 23, 1925.

Plate apparatus.—A condenser is built up of elements each comprising a pair of corrugated plate 43, 44 with crossed corrugations 45, 46 each at a small angle, say 10° from the

vertical. The elements are assembled in a casing 24 and are held to a back-plate 16 by bolts 18, 19 and blanking-plates 20, 21. Packing washers 22 are fitted between the elements and are of rubber, moulded to accommodate the corrugations and surround the inlet and outlet orifices 27^a, 28. Brackets 31 and rubber pads

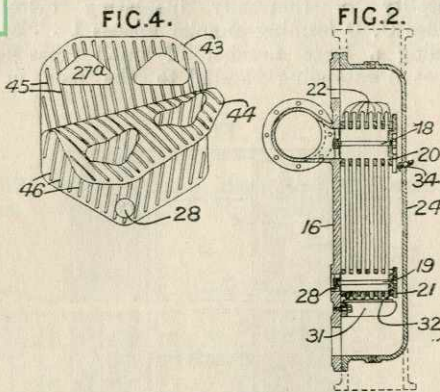

32 support the elements and a pad 34 prevents by-passing of the cooling water.

249,534. Chavanne, L. March 19, 1924, [Convention date].

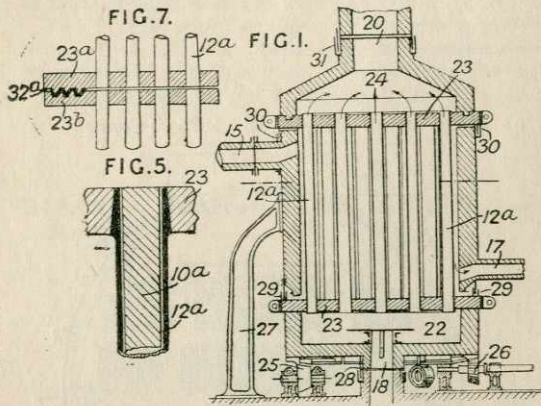

Straight tubes between headers; rotary straight-tube apparatus.—In continuous heat-exchange apparatus for fluids such as air gas &c. of the kind in which a nest of flues for the circulation of one of the fluids is rotated past the inlet of the other fluid, thus avoiding the formation of a hot zone at the inlet, the nest of tubes 12^a carried by upper and lower tube-plates 23 is rotatably mounted in a fluid-swept chamber the fixed surrounding wall of which is arranged intermediate the tube-plates and carries the inlet and outlet ports 15, 17. The tube-plates are connected to upper and lower chambers 24, 22, the whole being supported on rollers 25 and rotated by a pinion 26. Columns 27 support the stationary part of the apparatus. The gases to be heated enter at 18 and leave at 20, packings 28 - - 31 being provided where the rotary parts connect with the fixed parts. Refractory radiating bodies 10^a may be arranged within and around the tubes 12^a, which may be soldered to the plates 23 as shown in Fig. 5. For heating air to a very high temperature nests of tubes 12^a

are arranged in series, adjacent tube-plates 23^a, 23^b being jointed together by asbestos packing 32^a, Fig. 7. The material of which such nests of tubes and their internal and external radiating bodies are formed may be progressively of a less refractory nature as they become further removed from the hot-gas inlet or burner 15.

249,905. Fothergill, H., (*Wheeler Condenser & Engineering Co.*) Dec. 3, 1924.

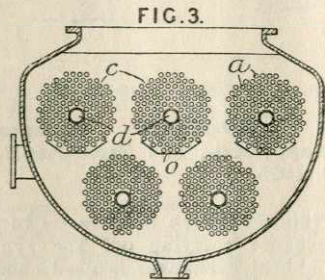

Straight tubes between headers.—Water tubes *a* are arranged in clusters *c* so spaced as to permit the entrance of steam to each cluster, and off-takes *d* are arranged within the tube clusters for the removal of uncondensed gases. The clusters are arranged to leave a free passage for the flow of steam to all sides of each cluster and trays or plates *o* prevent condensate falling on the lower clusters. Each take-off consists of a tube or conduit parallel with the water tubes and having inlet ports throughout its length. The off-takes are connected to a suction chamber through which the water tubes pass to cool the gases withdrawn by the off-takes. Specification 249,906 is referred to.

249,906. Fothergill, H., (*Wheeler Condenser & Engineering Co.*) Dec. 3, 1924.

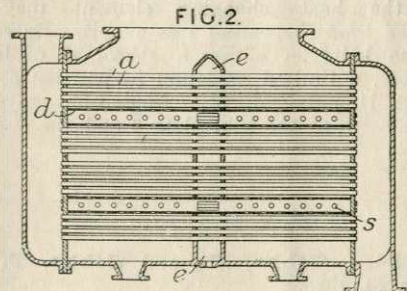

Straight tubes between headers.—A steam condenser has a suction chamber *e* to which the air-withdrawing means is connected, and uncondensed gases and aerated vapour pass into the

suction chamber through conduits *d*. The water tubes *a* pass through the suction chamber to condense vapour and cool gases withdrawn from the condenser, and the tubes are supported by the walls of the suction chamber. The water tubes are arranged in clusters and the uncondensed gases are withdrawn from the centre of each cluster through ports *s* in the wall of the corresponding conduit, which is closed at the end remote from the suction chamber. According to a modification, the suction chamber is formed at the side of the condenser by a partition and the conduits have open ends and extend to different lengths from the suction chamber to promote uniformity of flow into the suction chamber. Specification 249,905 is referred to.

250,086. **Priser, D. F.** Aug. 10, 1925.

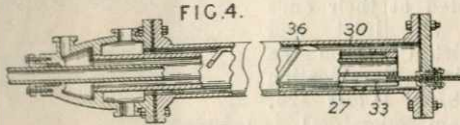

Concentric straight-tube apparatus.—Water to be heated by steam passes first through a tubular member 27 and then in the reverse direction through an outer casing 30. Steam passes in one direction only through the interspace 33. A spiral rib 36 may guide the water in the outer casing. In a modification, the central tube passes through an end casing and connects with the outer space by an exterior pipe.

250,169. **Compagnie Nationale des Radiateurs.** April 4, 1925, [Convention date].

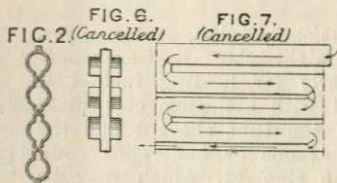
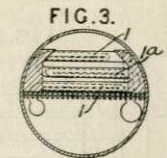
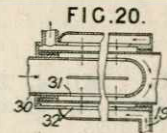
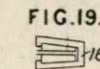
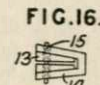
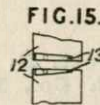
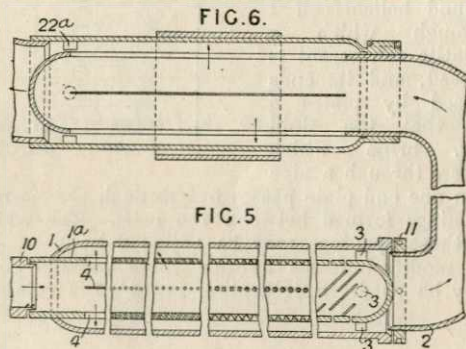

Plate apparatus.—A water-heater comprises a reservoir and a heating element formed by a hollow body adapted to be traversed by a hot fluid, the hollow element being formed of two shells connected at their edges, the plates being corrugated from end to end, as shown in section in Fig. 2, and discs or plugs being soldered or welded to the plates to close the ends of the

ducts formed by the opposed corrugations. In a modification, the plates are annular in form.

The Specification as open to inspection under Sect. 91 (3) (a) comprises also variations in the form of the flat elements, two of which are shown in Figs. 6 (*Cancelled*) and 7 (*Cancelled*). Others mentioned comprise tubular grid-like arrangements. This subject-matter does not appear in the Specification as accepted.

250,792. **Hagstedt, C. N. G.** June 26, 1925.



Concentric and field tube apparatus.—A heat exchanger comprises a series of concentric inner and outer tubes 1, 1^a, the inner tube 1^a being provided with radial apertures 4 throughout its length so that the fluid to be heated or cooled admitted thereto is discharged through the apertures in a radial direction against the inner surface of the outer tube which is maintained at the required temperature. The straight elements 1, 1^a may be connected up by bent pipes 2, 10 fixed in the main structure and a gas-tight joint is obtained by screwing out a threaded ring 11. Alternatively the extension 2 of the inner pipe 1^a may be made integral therewith and bent into semicircular shape to meet the next outer pipe as in Fig. 5. The inner pipe is supported on the outer by projections 3, 22^a, and a gas tight joint is obtained by forming the axially slotted shoulder 12 with projections 13, Fig. 15, which are forced together by a shaped strap 14

having a cotter pin 15, Fig. 16, or by a spring strap 16, Fig. 19. The pipes may be bent to form the bridge of a fire place Fig. 3, while in

Fig. 20 a fluid entering the pipe 30 passes through slots 31 to heat a fluid passing through a pipe 19 and slots 32.

251,024. Daniels, G. W. Jan. 24, 1925.

Coil-tube apparatus.—Apparatus for cooling fluids comprises a chamber having its walls formed by a closely wound helical coil 1 through which a volatile refrigerant is passed, and its ends closed by plates 4 so that the fluid e.g. brine which enters through a pipe 5 in one end plate passes out through the narrow openings formed between the coils. The width of these openings may be adjusted by bolts 4^x. In modified forms two or more parallel coils may be used. Specification 11015/15 is referred to.

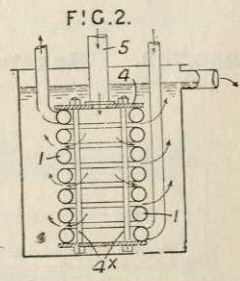

251,424. Roper, H. J. April 17, 1925.

Coil-tube apparatus.—A heater or cooler comprises a casing B and one or more composite tubes A formed from a number of tubes twisted together rope-fashion and arranged in coils or other formation in the casing and connected at their ends to an inlet and outlet C, D on the casing. Specification 5918/00, [Class 123, Steam generators], is referred to.

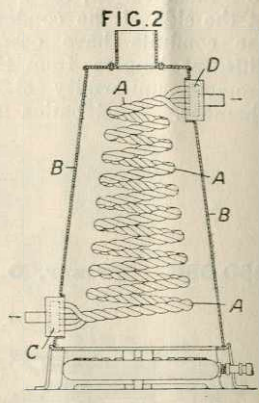

251,755. Miles, T. V., Allott, G. W., and Newton, Chambers, & Co., Ltd. April 17, 1925.

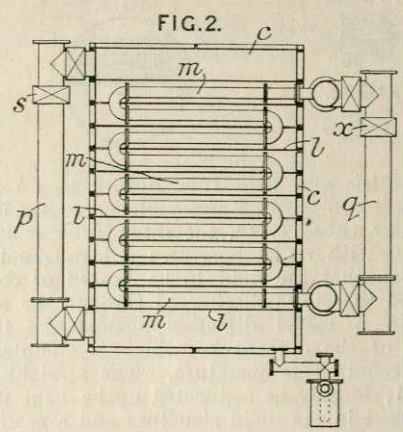

sists of removable flanged plates *c*, and baffle-plates *l* direct the hot gas in a sinuous path. The cold gas passes through sinuous tubes *m*, and bye-pass pipes *p, q* with valves *s, x* are provided.

Serpentine-tube apparatus.—The shell of a heat exchanger used in purifying cool gas con-

252,125. Griscom-Russell Co., (Assignees of Nelson, E. H.). May 14, 1925, [Convention date].

Expansion of tubes, providing for.—A straight-tube heat-exchanger particularly for heating fuel-oil is provided with a flexible connection between the tube sheet 4 and the shell 1 at one or both ends comprising a ring 12, which may be integral with the tube plate or welded thereto as shown, with a groove 18 separating off a part 19 which is welded or riveted to the shell.

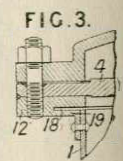

252,133. Soc. Anon. des Etablissements Delaunay Belleville. May 14, 1925, [Convention date]. Void [Published under Sect. 91 of the Acts].

Loop tube apparatus.—A heat-exchanger more particularly for heating oils is so constructed that the steam tubes 6, 7, with the header can be withdrawn as a whole from the cylindrical shell 1. Baffles 8 are plates resting on the tubes. A frame work on rollers 14 may support the free ends of the steam tubes.

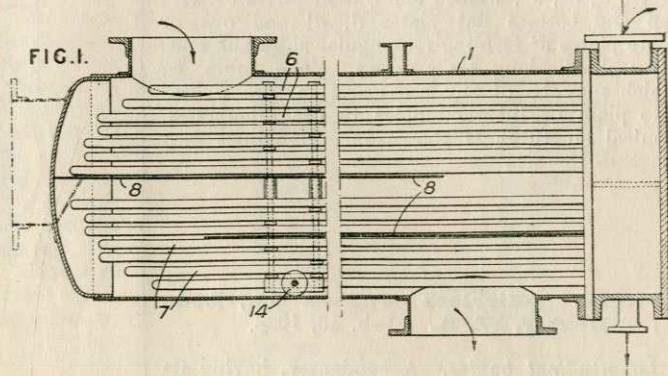

252,373. Maschinenfabrik Ing. H. Simmon. May 19, 1925, [Convention date].

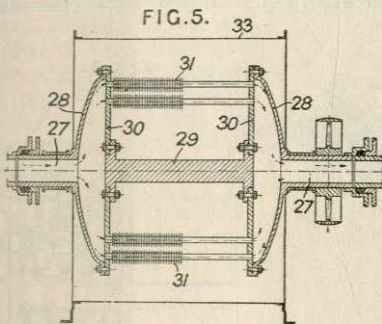

Rotary straight-tube apparatus. — A hollow ribbed drum traversed by one medium is rotated in a ventilator casing through which the other medium is moved by the friction between the medium and the ribs, which extend in the direction of the rotary movement i.e. substantially perpendicular to the axis of rotation of the drum. In a modification intended for heating liquids the rotatable body comprises two hoods 28, Fig. 5, connected to discs 30 fixed to a spindle 29, the hoods being mounted on hollow journals 27 for the supply and discharge of the liquid. Ribbed pipes 31 are mounted between the discs 30, and the body is enclosed in a casing 33 with inlet and outlet openings for the hot gases arranged so that the body moves the hot gases through the casing by fluid friction. Centrifugal action causes the cold liquid in the inlet hood 28 to displace the heated liquid in the pipes 31 rendering a pump unnecessary. Adjustable deflecting plates for the hot gases may be fitted in the casing.

The Specification as open to inspection under Sect. 91 (3) (a) comprises also statements that the ribs may be omitted or replaced by pins. This subject-matter does not appear in the Specification as accepted.

254,100. Montey, H. G., and Elson, J. A. June 23, 1925.

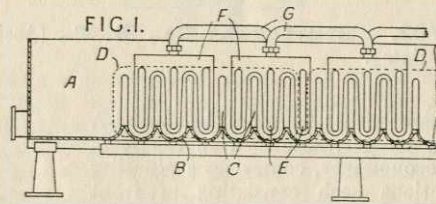

Trough and open channel apparatus. — Beer, milk &c. to be cooled flows through a trough A corrugated at the bottom, while water or other cooling-medium flows through groups of tubes C, which are permanently fixed to the apices of the corrugations B and are connected to detachable headers D outside the trough, and also through bodily removable groups of tubes E connected to headers F. The tubes C, E may consist of single tubes with corrugated walls, or a set of square, round or other tubes secured together to form an upright wall.

254,600. St. George's Engineers, Ltd., Purslow, H., and Anderson, J. Dec. 11, 1925.

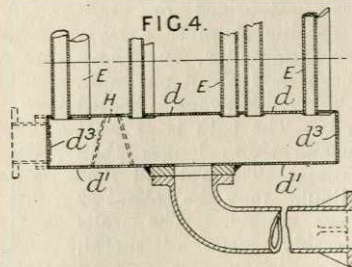

Headers.—A radiator shown as applied to a

transformer cooling-tank is constructed with headers formed of a number of separate flat plates d, d^1, d^2 , welded along their edges or with top and bottom flat plates d, d^1 and one or more plates d^2 forming rectangular sides and ends all welded along their edges. The tubes E, which may be of any cross section, are welded into plain or inturned holes in the tube-plates. Conical air tubes H shown in dotted lines may traverse the headers.

254,626. Mirrlees Watson Co., Ltd., and Dexter, W. A. Feb. 13, 1926.

Longitudinal baffles.—A condenser, having its broadest part at the bottom, is provided with an air cooling space 24 under a baffle formed by double-plates 1A, 2A, the space between commu-

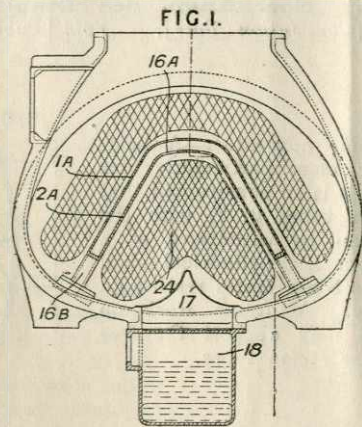

nicating by holes 16A with the space 24 and by ducts 16B with the air pump. A hood 17 covers the hot well 18.

254,702. Sturtevant Co., B. F., (Assignees of Derry, G. C.). July 6, 1925, [Convention date].

Straight tubes between headers.—A heat-exchanger, described in the form of an economizer, comprises a plurality of sections each consisting of front and back steel headers 6, 7, joined by steel tubes 8 which may be gilled, adjacent front headers being connected by U-bends 17 and each section being independently mounted as on angle-irons 23. Each front header has a partition 18 to separate the inflow from the outflow. The tubes are centrally supported on a cross-member resting at its ends on the angle-irons 23. The tubes may be arranged in staggered relation to those in adjacent sections.

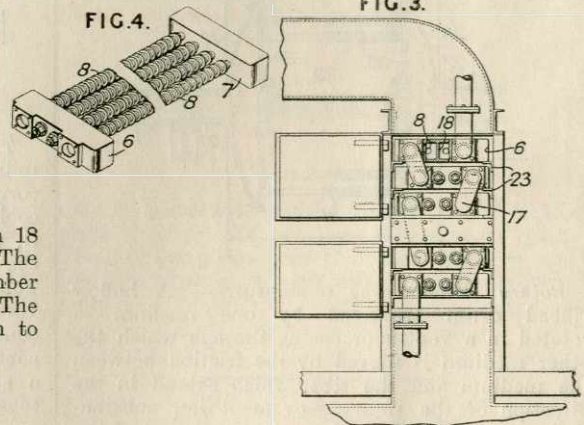

254,725. Stassano, H. July 1, 1925, [Convention date].

Concentric straight-tube apparatus.—Liquids, such as milk or beer, are pasteurized or sterilized by passing them in a layer endless e.g. annular, in transverse section and about one mm. in thickness between heated metal walls. The path is at least ten thousand times longer than the thickness. The rate of flow of the liquid may be about 2 metres per second. The walls are preferably made of metal, such as copper, having a good conductivity and a low thermal capacity, and may be maintained

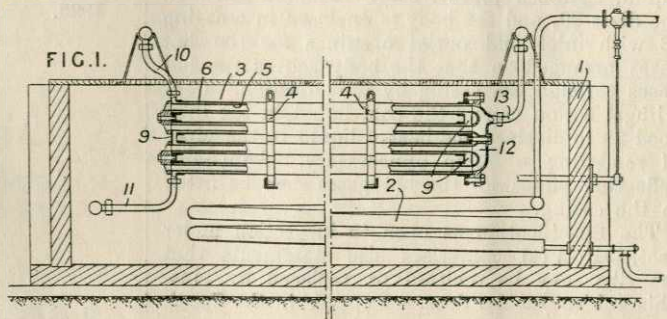

at a temperature of 70—75° C. for pasteurization and of 120—135° C. for sterilization. Milk may be completely pasteurized at a temperature of 70—75° C. in about 8—10 seconds by flowing it along a path 8—10 mm. thick and at least 10 m. long at a rate of 2 m. per second. Copper tubes are preferred to aluminium. In the apparatus described, the liquid flows from pipe 10 through the annular spaces 6 formed between a series of coaxial tubes 3, 5 supported by members 4 in a container 1 filled with liquid heated by a steam &c. coil 2. Passages 9 connect the spaces 6 at alternate ends, the liquid flowing out through pipe 11 after traversing successively all the spaces 6. The liquid in container 1 is circulated by a pump through a pipe 13 and unions 12 to the interiors of tubes 5, to keep their temperature uniform.

255,711. Munday, R. L. Dec. 5, 1925.

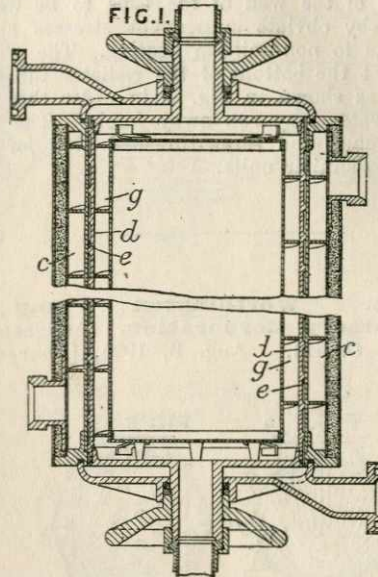

254,959. Vergés, R. C. Nov. 23, 1925.

Honeycomb and like tube apparatus.—Radiator tubes are formed with a number of ribs or flutings and at their ends are widened to form mouthpieces of rhombic shape, 7, which are fitted together and soldered to form the front and rear faces of the radiator. The tubes may be produced by drawing through a draw plate, or by electro-deposition, or they may be made from sheet metal. Specification 208,136 is referred to.

FIG. 2. FIG. 4.

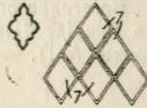
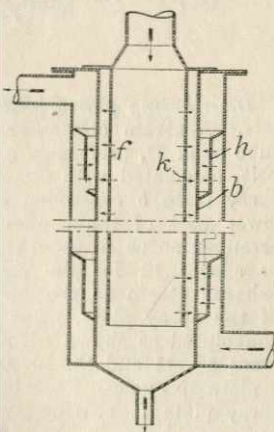

Plate apparatus.—A method of heat-exchange for fluids consists in passing the fluid to be treated, for example milk to be sterilized, through a shallow spiral conduit *e*, disposed, around a cylindrical shell, *d* so as to be in continuous heat conducting contact with coaxial inner and outer spiral conduits *g*, *c*, through each of which the treating fluid passes in a direction counter to that of the fluid to be treated.

255,364. Lütchen, E. March 3, 1926.

Plate apparatus.—A heat-exchanger of the type in which one fluid is directed against the heat exchanging wall, is provided with perforated partitions *f*, *h* parallel with and a short distance from the wall *b* so that jets of fluid passing through the perforations *k* impinge with equal velocity against the heat exchanging surface. The partitions may be on one, or both sides as shown.



256,185. Mannesmannröhren-Werke. July 30, 1925, [Convention date].

Headers.—In a radiator wherein the tubes *b*, which are pressed out of sheet iron and welded at the seams or are made out of thin-walled seamless tubes, are inserted in slots *c* in connecting hubs *a* and welded thereto, the hubs have internal cavities of the external breadth of the tubes so that the lateral sides thereof will support and guide said tubes over a wide surface and so relieve stresses at the welded joints. The edges of the hubs are shaped or

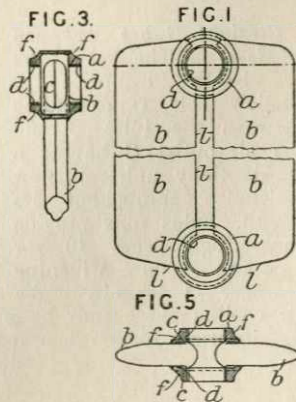

recessed as at *f*, Fig. 5, so as to reduce the thickness of the metal at the weld to equal the thickness of the wall of the tube to be welded and thereby obviate subsequent stresses at the joints due to non-uniform heating. The welded seams *l* at the bottom of the radiator tubes are inclined as shown in Fig. 1 in order that condensed water may run away freely. The hubs are thickened and screw-threaded at *d* for connection to similar units.

256,214. Worthington Pump & Machinery Corporation, (Assignees of Lucke, C. E.). Aug. 3, 1925, [Convention date].

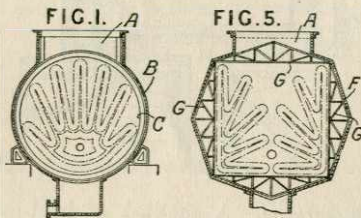

Casings.—The shell B of a condenser is made of comparatively light material reinforced by spaced-apart members C outside the steam condensing space, either inside or outside the shell. The members C may extend across the inlet A for steam. In Fig. 5 the supports form bracing frames G of triangular form within the casing F.

256,215. Worthington Pump & Machinery Corporation, (Assignees of Lucke, C. E.). Aug. 3, 1925, [Convention date]. Grant of Patent refused.

Straight tubes between headers.—The tube bank or banks comprise a shallow belt D extending between the inlet B and the air outlet C having a substantially uniform flow resistance throughout its length. Folds may provide contacting spaces 10 for steam and widening passages 11 for air. An air cooling space may be protected by a baffle. Specification 169,977 is referred to.

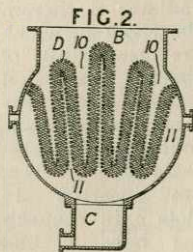

256,579. Griscom-Russell Co., (Assignees of Jones, R. C.). Aug. 5, 1925, [Convention date].

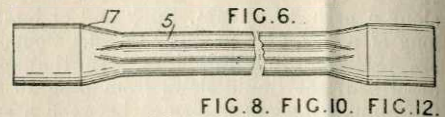

Tubes of special section.—Oil or other viscous liquid to be heated or cooled is passed through heat-transferring tubes shaped so as to flatten out the streams passing through them. Examples of suitable tubes 5 are shown, that in Fig. 6 having cylindrical ends and tapering portions 17 joining the ends to the central deeply corrugated part. Figs. 8, 10 and 12 show other cross sections. In the preferred complete apparatus the tubes are secured at the end to a tube plate in a divided inlet and outlet header the other ends being connected to a floating header either wholly within the external casing of the apparatus or sliding within the cylindrical side wall and forming the end closure of the casing. Specification 142,715 is referred to.

Reference has been directed by the Comptroller to Specifications 120,184; and 139,716, [Class 18, Boxes &c.].

256,594. Worthington Pump & Machinery Corporation, (Assignees of Lucke, C. E.). Aug. 5, 1925, [Convention date].

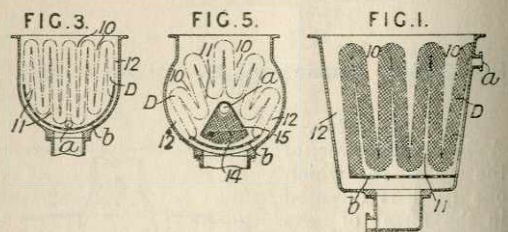

Distributing plates in fluid outlets.—A steam condenser has its tube bank D, preferably a shallow belt, associated with a condensate spray plate *b* extending over the lower part of the condenser and arranged so as to provide a space or spaces 12 for the passage of exhaust steam to the lower side of the spray plate. The belt of tubes may be convoluted as shown with tapering steam and air lanes 10, 11 and the air offtake *a* may be under a plate 15 enclosing a tubular air cooler 14. The spray plate is provided with water-sealed apertures as shown in Figs. 8, 8^a.

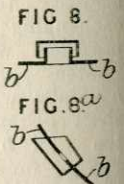



256,595. Worthington Pump & Machinery Corporation, (Assignees of Lucke, C. E.). Aug. 5, 1925, [Convention date]. Grant of Patent refused.

Straight tubes between headers.—The tube belt D in a steam condenser is shallow, convoluted, encloses the air-offtake a, a, and is surrounded by a steam space 12. It is constructed so as to afford a substantially uniform flow resistance throughout its length. More than one belt may be provided in the condenser. The air-offtake may be shielded by a plate 15, Fig. 8 enclosing an air-cooler 14.

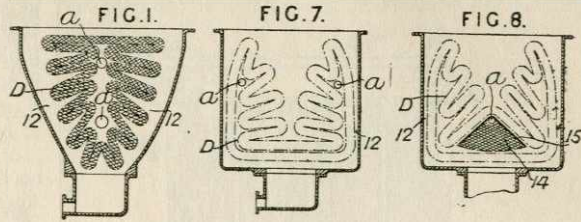

256,596. Worthington Pump & Machinery Corporation, (Assignees of Lucke, C. E.). Aug. 5, 1925, [Convention date].

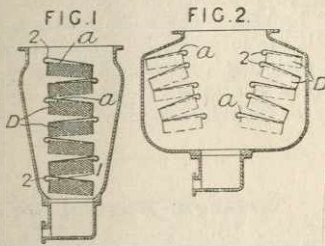

Straight tubes between headers; drip-interception devices.—A plurality of tube-banks D of substantially uniform flow-resistance in a condenser, are provided with an air chamber on the outlet face of each bank connected to a separate air offtake. In Fig. 1 the banks are superposed and the air chambers 1 and air off-takes 2 are formed by plates a extending over the upper surface of each bank. In Fig. 2 a double set of banks is provided.

The Specification as open to inspection under Sect. 91 (3) (a) comprises also constructions in which a single air-offtake is used in connection

with a plurality of tube banks. This subject-matter does not appear in the Specification as accepted.

256,693. Harris, T. H. May 13, 1925.

Tubes of special section.—A tube or tubular element applicable to surface apparatus such as condensers, coolers, heaters, evaporators, &c. is obtained by forming in each of two metal surfaces a number of hemispherical domes b, the surfaces being placed together in such a way that the cavities overlap as shown, thus forming a sinuous passage for the fluid. The tube or tubular element may be formed from a single sheet with an even number of rows of cavities so placed that when the sheet is folded the cavities come together in the required way. The joints may be brazed, welded or soldered, and the ends may be tapered to fit into a head plate or cross pipe.



258,888. Norddeutsche K hlerfabrik Akt.-Ges. Sept. 23, 1925, [Convention date].

Plate apparatus.—An aircraft radiator comprises a number of interchangeable units each consisting of one or more layers of flat tubes a the open ends of which are secured within overlapping parts of the walls of border tubes b, so that the tubes a are tangential to the walls of the border tubes, as shown in Fig. II. The border tubes are arranged side by side so as to bring the elements close together, and adjacent pairs of border tubes are soldered to tubular sections c of built-up corner pillars or

headers p, p¹, p², p³, each cooling element thus comprising two plates with their border tubes and four corner sections. The sections c have a groove at one end to receive a packing ring and a flange at the other end to seat on the packing of an adjacent section. The sections are secured together between a top casting f and a lower cover d by a bolt e secured to the casting f, the threaded part of the bolt being surrounded by a sleeve h to prevent corrosion. The plates are spaced by 17-shaped members fastened thereon and provided at the middle of each side edge with sleeves for the reception of bolts o, Fig. III, to hold the plates rigid. The pillar castings f are provided with

sockets *m* for side suspension rods *n*, and two of them have pipe connections *i*, *j* for inlet and outlet of water. For small radiators only two pillars need be used as water passages, but for

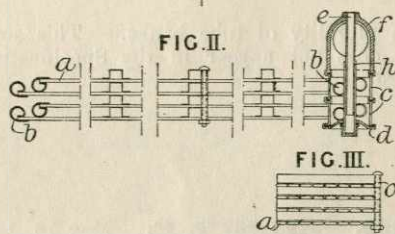
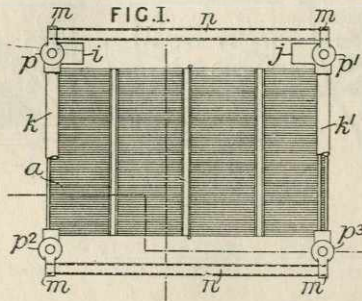

larger radiators all four are connected in the circuit by means of tubes *k*, *k'*, Fig. I. The tubes are set transversely to the cooling-air current.

258,912. Parsons, Sir C. A. March 30, 1925.

Facilitating flow of fluid.—A screen is arranged in the water-box of a condenser, at the entry end, in front and spaced apart from the tube-plate, comprising a series of juxtaposed ducts with their axes parallel to the axes of the main tubes, the ducts being long in relation to their transverse dimensions and the number being preferably large in relation to the number of the condenser tubes. Two screens A, B may be used. The screens may be made of corrugated plates soldered together, of a number of juxtaposed short tubes, of a drilled solid plate, or of a number of tubes projecting from a tube plate. Each duct thus formed may be subdivided by plates inserted in the bores.

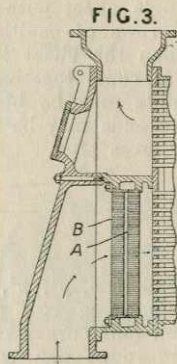

258,984. Bull, A. W. H. July 29, 1925.

Straight tubes between headers.—The upper and lower header chamber *a*, *b* of a motor-vehicle radiator are secured together, with the detachable tubular element and side frames between them, by means of bolts *g* passing through tubes *f* of rather larger bore than the cooling-tubes *e*, the bolts being screwed or otherwise fixed in one of the headers, for example in lugs *g'* in the top header, and passing through the other header. The lower ends of the bolts have threaded on them sleeves *h* integral with external nut heads, packing washers *i* being interposed between the nut heads and the outer wall of the header. The sleeves *h* have collars *n'* inside the header to prevent the bolts from dropping out when broken. The tube plates *c* and the header walls are formed with co-operating grooves *k*, *k'*, or with flat or inclined surfaces, for the reception of a continuous joint ring *l* of rubber, of circular or angular section.

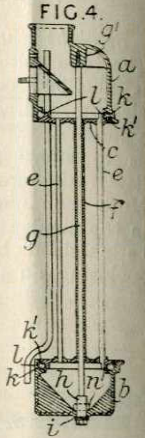

259,182. Griscorn-Russell Co., (Assignees of Price, J.). Sept. 29, 1925, [Convention date].

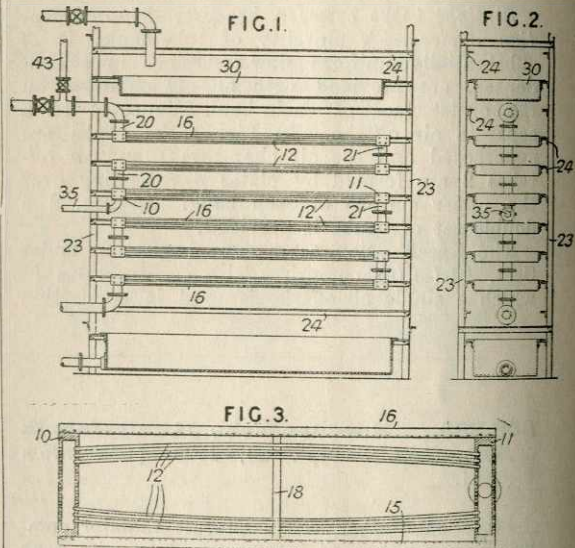

Bowed tubes between headers.—A heat exchanger for use with water liable to form scale comprises a number of units each formed by a pair of headers 10, 11 joined by bowed tubes 12 and spaced apart by angle bars 15, 16 of less expansibility under heat than the tubes, mounted in a framework 23, 24 and connected with one another by projecting tubes 20, 21. Water is

sprayed from a tray 30 or from perforated pipes or the exchanger is immersed in a tank. When used for condensing oil vapours, fractional condensates can be drawn off at intermediate headers as at 35. Scale can be cracked off by passing steam through the tubes by pipe 43, the tubes being caused to bow laterally under expansion by cross bars 18 between and above and below the rows of tubes.

are used, in order to allow some longitudinal movement of the steam. The water headers may be divided by partitions 4 so as to cause the water to have two or more passes across the condenser, and the lines of division between the plates 11, 12 may follow the lines of separation between the passes.

259,276. Millard, R. B., and South-western Engineering Corporation.
June 22, 1925.

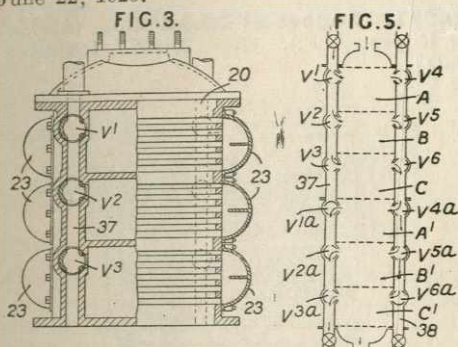

Headers.—In a surface condenser in which cooling tubes pass across a vapour space 20, inlet and outlet passages 37, 38 for the cooling medium are connected to liquid distributing channels by valves $V^1 - - V^6$, $V^{1a} - - V^{6a}$ or closing plates so that the cooling medium may be passed in series or in parallel through the units, or one cooling medium such as water may be used in some units and a second medium such as oil to be preheated may be used in others. The condenser is formed in sections divided into units A, B, C, A^1 , B^1 , C^1 . Each unit is fitted with separate end covers 23, Fig. 3 which may be divided by partitions so as to cause the cooling medium to have one, three or five passes through the cooling tubes. When a second cooling medium is used, one of the end covers or one of the valves V may be fitted with a liquid-inlet passage.

259,306. English Electric Co., Ltd., and Mather, J. W. July 8, 1925.

Tube-supports.—In heat-exchange apparatus such as surface condensers in which cooling water passes through a nest of parallel tubes connecting headers 2, 3 and steam passes through an inlet 9 to an outlet 10 across the tubes, tube-supporting plates 11, 12 extending only partially across the steam space

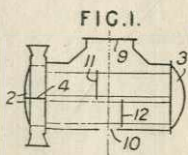

259,824. Dehn, F. B., (Jacobi, Akt.-Ges., A.) March 12, 1926.

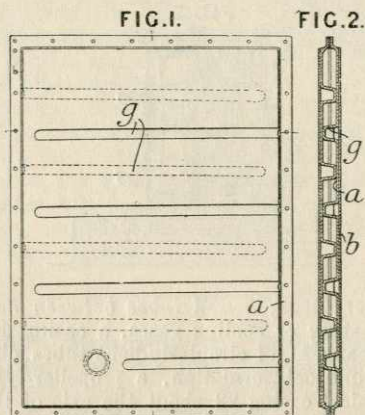
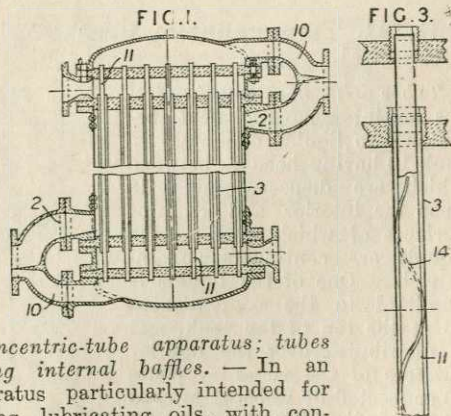

Plate apparatus.—Two or more pressed-out metal plates *a* are provided with projecting ribs or walls *g*, and assembled so that the projecting ribs on the plate lie between those on the other plate in order to provide a sinuous path for the heating or cooling medium. Plates *b* may be applied to give a flat external surface. The ribs may be formed from tongues of metal cut and bent out from the plates *a*. The edges of the plates may be welded to frame members of solid or of channel section.

260,066. Storoni, E. Aug. 12, 1925.



Concentric-tube apparatus; tubes having internal baffles.—In an apparatus particularly intended for cooling lubricating oils, with concentric tubes 3, 11 between which the oil flows, and separate inlets and outlets 2, 10, for the heating or cooling fluids



whereby the flow may be on one or both surfaces of the annular spaces, the difference between the inner radius of the tube 3 and the outer radius of the tube 11 lies between 0.5 and 2 mm. The space is kept constant by a spiral continuous or interrupted wire 14.

260,357. Potts, J. Forgan. July 30, 1925.

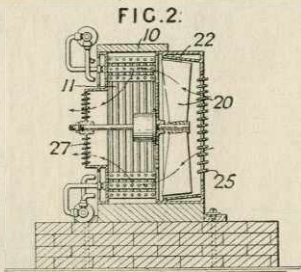

Gills for tubes; bowed tubes between headers.
 —For heating or cooling gases, a casing 10 contains a bank 11 of circularly-bent tubes disposed in a cylindrical formation, a propeller-type fan 20, a conical casing 22 about the axis of the fan to receive the air delivered therethrough and heat-transmitting vanes (not shown) secured on the tubes and angularly disposed so as to present edges only to the substantially spiral air-flow through the casing.

260,759. Chew, J. S., and Parkinson, A. Oct. 23, 1925.

Gills for tubes.—In a motor-car radiator corrugated strips A of metal are perforated at each succeeding crest and hollow with holes a that may be used for the passage of tubes B through

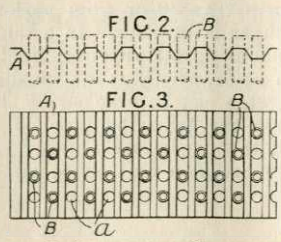

which the circulating water flows, and on which the strips are threaded in such a manner as to form a hexagonal-cellar honeycomb structure.

260,941. Ingersoll-Rand Co., (Assignees of Kirgan, J. F.). Nov. 3, 1925, [Convention date].

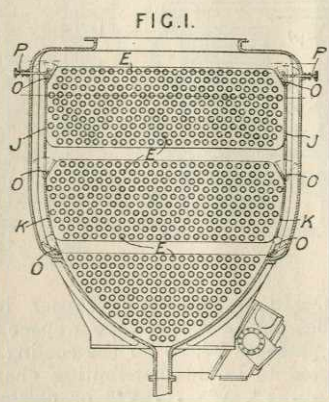

Casings.—A surface condenser is provided with means for bye-passing steam about certain of the groups of tubes E to other groups nearer the outlet for non-condensable gases and with walls J, K, for preventing steam from entering at the sides of the bye-passed group. In the example shown the amount of steam bye-passed is controlled by valves O operated by rods P.

261,731. Guggenheim Bros., (Assignees of Burdick, C. L.). Nov. 21, 1925, [Convention date].

Tubes with nozzles.—Apparatus for interchanging heat between two liquids comprises a tank 10 having headers between which are disposed tubes 16 upon the interior and exterior surfaces of which films of the liquids are continuously maintained. One of the liquids is admitted to the compartment 13 at the top of the tank, and is distributed over the interior surfaces of the tubes by cones 30 connected by webs 31 to caps 27 having liquid inlet orifices 29 and inserted in the upper ends of the tubes while the other liquid is distributed over the exterior surfaces by a tray 20 having openings

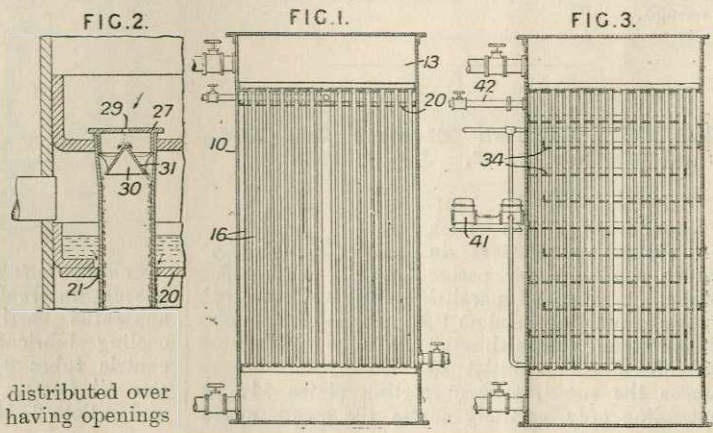

21, the diameter of each opening being slightly greater than that of each tube. Fig. 3 shows apparatus in which the liquid, such as brine, flowing down the insides of the tubes is cooled by a refrigerant liquid, such as ammonia, which is distributed over the outsides of the tubes by trays 34. The vaporized refrigerant passes through the pipe 42, while the unvaporized refrigerant is withdrawn from the lower part of the tank and recirculated over the tubes by a pump 41.

262,452. Fuchs, A. Dec. 3, 1925, [Convention date].

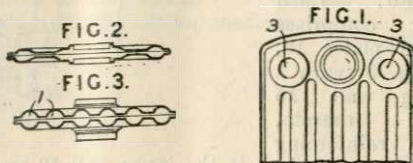
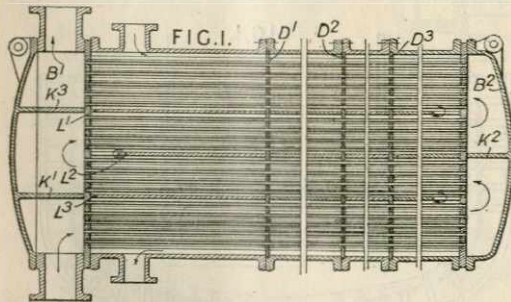

Plate apparatus.—The elements of a radiator comprise metal plates stamped with longitudinal channels 1 and depressions 3 adjacent to the connecting-apertures at the top and bottom of the elements. The plates, which may be from 0.6 to 1 mm. in thickness, are welded together at their edges and between the longitudinal channels.

263,585. Higgins, C. F. Nov. 4, 1925.



Straight tubes between headers; casings; longitudinal baffles.—A casing is made in sections, partitions D^1 , D^2 , D^3 , with ports on opposite sides alternately, separating compartments through each of which tubes pass from end headers B^1 , B^2 . Longitudinal baffles L^1 , L^2 , L^3 cause the medium outside the tubes to pass in a serpentine manner vertically the cross partitions D^1 , D^2 , D^3 giving it a zig-zag path in each plane. Partitions K^1 , K^2 , K^3 in the headers cause the medium within the tubes to make several passes across the apparatus in a general direction counter to that of the medium outside.

263,649. Randle, F. Feb. 1, 1926.

Headers.—In motor-car radiators of the type in which upper and lower headers are detachably secured to the tube plates of a tube block by bolts passing through the block, these bolts 8 are threaded into loose bridge-pieces 10 inside the upper header 2. The bridge-pieces preferably rest on an in-turned flange 20 of the header between which and the tube plate 5 is a packing washer 7.

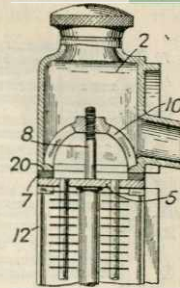

Side frame members 12 may be provided between the headers. According to the Provisional Specification the face of the header may extend beyond and conceal the joint with the tube plate, the joint washer may be a flat endless ring cut out of a sheet, and the tube plates may be of rolled sheet or strip brass.

263,818. Popescu, T., Pais, A., and Pais, C. Dec. 23, 1925, [Convention date].

Tubes or passages formed in blocks.—In a heat-storing block used for heating feed-water, a system of closed connecting passages contains a volatile liquid such as water, alcohol or ammonia to equalize the temperature of the block. The water-heating passages may be in the form of external pipes 50 having a broad flat surface 51 in contact with one face of the block 30.

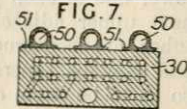

264,377. Morgan, G. U. May 17, 1926.

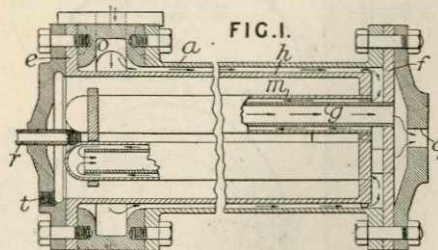

Field-tube apparatus.—At each end of a generally cylindrical casing a a tube support e , f is fitted one, e of which is extended within the casing to near the other and carries the closed-ended outer tubes m , the inner open tubes g being borne by the other support f . In the example shown, for heating fuel oil, the oil enters at o , passes between the extension h and the casing to traverse the Field-tubes and flow out at q . Steam for heating enters at r and condensate escapes at t .

264,746. **Babcock & Wilcox, Ltd.**,
(*Babcock & Wilcox Co.*). Aug. 16, 1926.

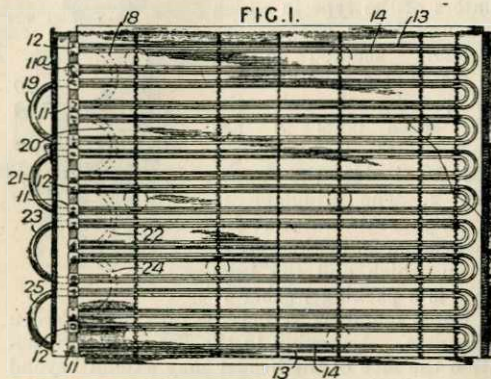

Loop-tube apparatus.—In a fluid-heater of the economizer type having a plurality of headers 11, 12 extending across the flue at one side and one above the other, and U-tubes 13, 14 connecting each pair of adjacent headers, the fluid inlet 11a is fitted into the header next below the topmost header and the outlet to the header next above the lowermost, and connections 18 - - 25 are arranged between the headers to connect the lower one of each pair with the upper one of the next upper adjacent pair of headers. The U-tubes are constructed of different sizes 13, 14 and may be tapered in towards the looped end, so as to be more of V-formation.

265,201. **British Thomson-Houston Co., Ltd.**, (*Assignees of Stephens, H. O.*).
Jan. 28, 1926, [*Convention date*].

Headers.—The radiator tubes 12 of an electric transformer tank 17 or other electrical apparatus are connected to upper and lower headers 10, 11 arranged with their main walls vertical so as not to impede the upward flow of cooling-air. Each header comprises vertical plates 13, 14, Fig. 3, with a spacing wall 15 welded thereto, and a reinforcing strip 18 is welded on to the inner wall 13 around the opening communicating with the branch pipe 16, Fig. 1, of the tank. The strip 18 is formed with internal shoulders to support a number of tubes 20 welded to the header walls and accommodating the bolts connecting the header to the flange of the branch. The tubes 12 may be flattened, and are offset from the header walls as shown.

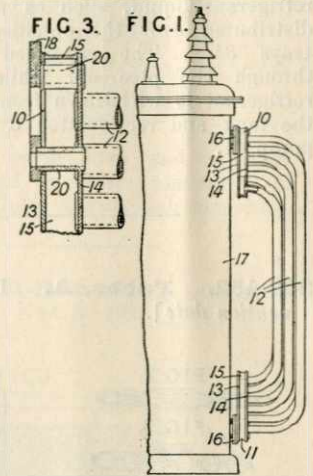

265,133. **Pfaunder Co.**, (*Assignees of Nichols, E. B. and Todd, U. G.*). Jan. 27, 1926, [*Convention date*].

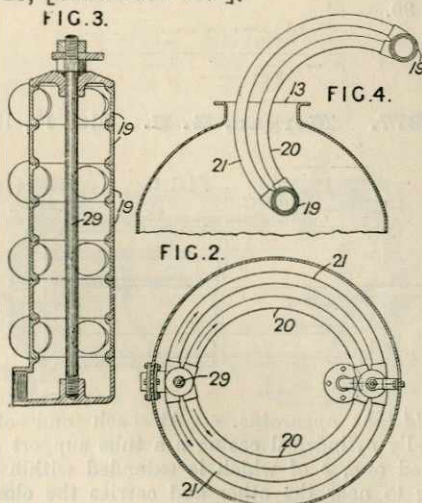

Headers, construction of; bowed tubes between headers.—A heat-exchanger has tubular elements 20, 21 of arcuate shape, such as can be passed longitudinally into a container through a manhole 13. The elements are secured within the container by tie rods 29 passing through the ends 19 clamping them together to form headers.

265,597. **Hadamovsky, P.** Feb. 3, 1926, [*Convention date*].

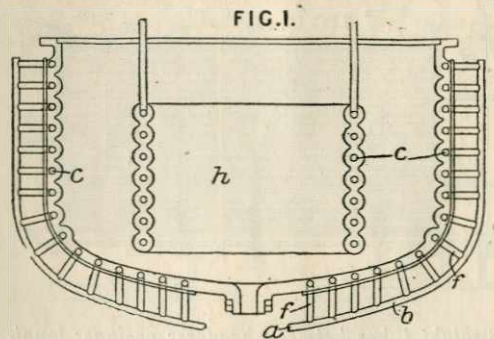

Plate apparatus.—The wall surfaces of vessels, or of heating or cooling elements, having embedded therein pipes conveying steam, cooling-brine or other medium, are shaped, preferably, by waving or corrugating, so that nearly all parts of the wall surface are equidistant from the pipes, whereby a better heat exchange and economy of material are effected and liability to corrosion is diminished. The pipes c may be of wrought iron embedded in cast iron walls. Steam may be admitted at a to a pipe b connected by branches f with the several pipes c, which have condensa-

tion outlet branches. The elements *h* inside the pan may be similarly formed. The invention is applicable to pans used in evaporating, crystallizing and sublimating processes, and to flat or roller shaped elements.

265,845. Dehn, F. B., (*Jacobi, Akt.-Ges., A.*). June 22, 1926.

Plate apparatus.—A plate *n* applicable for cooling soap is constructed with stays *g* made of pressed metal, forming a sinuous passage for the cooling medium.

FIG. 2.

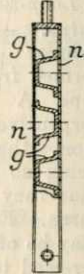

267,225. Royles, Ltd., and Millington, W. E. W. Dec. 11, 1925.

Headers.—Compartments in the header of a multi-pass tubular heat exchanger directing the flow of medium through the tubes *b* are formed by partitions *d* integral with the tube plate *c* covered by a thin plate *f* held in place partly by pressure and partly by screws *f*¹.

FIG. 1.

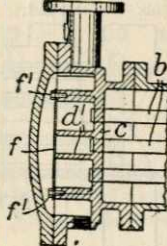

267,377. Matzka, W. Sept. 5, 1925.

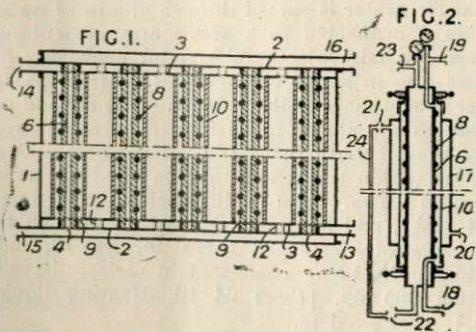

Concentric or jacketed straight tube apparatus; materials.—In apparatus for sterilizing liquids by heating, more especially according to the process

of Specification 267,058, [*Class 49, Food &c.*], the liquid flows in parallel through a number of elements heated by the circulation of hot water and each comprising an outer aluminium tube 10, Fig. 1, and an inner copper tube 6 having grooves containing gold rings 8. The ends of tubes 6, 10 are supported in apertures 4, 9 in plates 2, 3 in a casing 1. The liquid enters at 13, passes between the lower plates 2, 3, then between tubes 6, 10 and between upper plates 2, 3, and out at 14. Hot water for heating is supplied at 15 and passes up through tubes 6, and also through tubes 12 to between tubes 10, passing out at 16. In a modification, Fig. 2, a single pair of tubes 6, 10 is provided, the liquid flowing, under pressure if desired, in at 18 to between the tubes, and out at 19. Hot water for heating flows from 20 to 21 through the iron jacket 17 of tube 10 and from 22 to 23 through tube 6. The outlet 21 and inlet 22 may be connected by a tube 24.

268,093. Kearsley, G. W., and Tomkins, F. E. Feb. 10, 1926.

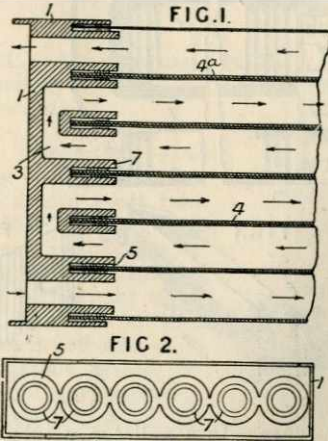
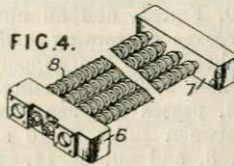

Plate apparatus.—A milk cooler of the type in which milk flows over cooling-tubes comprises a number of horizontal straight tubes 4, in contact along their lengths, and inserted into annular recesses 5 in a header 1. Molten solder is run into the grooves 5, and is prevented from overflowing by upstanding parts 7. U-shaped passages 3 are provided in the headers to enable the cooling medium to flow in a zigzag path through the tubes. Molten solder may also be run into the joint 4^a between the tubes. The tubes may be of tinned copper or stainless steel, and the headers of gun-metal or steel.

269,560. Sturtevant Co., B. F., (Assignees of Derry, G. C.). July 6, 1925, [Convention date].

Straight tubes between headers. — A section of tubes for a heat-exchanger comprises front and rear headers 6, 7, equally-spaced tubes 8 extending between them, the outer tubes on each side being at differing distances from the ends of the headers so that by arranging alternate sections in inverted relationship the tubes will be staggered in the apparatus. The inlet and outlet connections, which may be at one end of the section, are in the outer face of the header.



269,851. Trane, R. N. April 23, 1926, [Convention date].

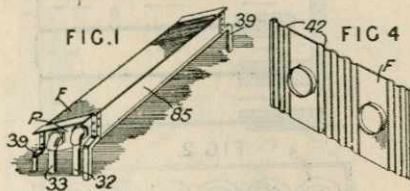
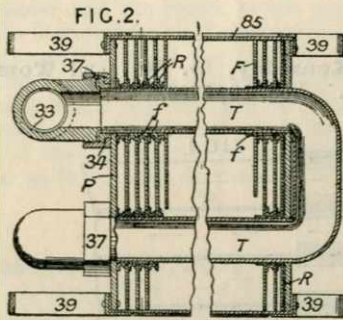

Gills for tubes.—In a radiator, a tube conveying heating fluid carries a number of spaced fins which are flanged and provided with ferrules to ensure good heat contact with the tube. The radiator, Figs. 1 and 2, comprises a pair of pipes T provided with fins F of very thin sheet metal, having flanges f which are tightly held on the tube by ferrules R. The outer ends of the fins are protected by plates 85, extending between the end plates P and flanged over them, the whole being secured by angle irons 39 which are extended to form legs for the radiator. The tubes, fins, and ferrules are preferably of copper, the tube being 0.02 inches thick, the fins 0.007 inches, and the ferrules 0.03 inches. The pipe connections 32, 33 are coupled by means of a flanged collar 34 and nut 37. The tubes T may be circular, or elliptical, with the longer diameter vertical. The fins F may be provided with cor-

rugations 42, Fig. 4, which may be parallel in adjacent fins, or may be arranged to give a honey-comb construction to the assembled radiator. The tubes T may be expanded against the ferrules by internal pressure or by a tool.

270,148. Crittall, R. G., and Musgrave, J. L. Sept. 9, 1926.

Loop-tube apparatus. — A rigid tubular grid is formed from a single pipe A bent into serpentine formation, the turns a' being so constructed that they can be directly secured to adjacent turns. Each length of pipe between the turns may be of serpentine form contiguous beads being screwed together.



270,250. Leek, A. E. May 1, 1924, [Convention date].

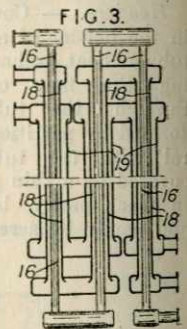
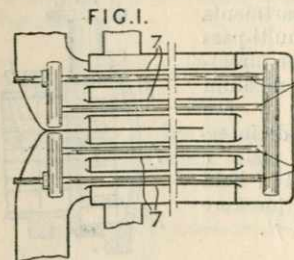

Concentric-tube apparatus. — In a heat-exchanger, water is passed through groups of water-tubes 1 connected in a series arrangement disposed coaxially within tubes 7 for conveying hot gases also in series arrangement. Air is passed over the surfaces of the tubes 7. The air and gas passages are stated to be formed so as to avoid any rapid change in cross sectional area. Dead spaces within the casing may be filled by baffles or cross plates. In a modification, Fig. 3, water, hot gases, and air pass respectively through the concentrically arranged tubes 16, 18, 19, individual units being connected in series. Specification 260,083, [Class 64 (i), Heating liquids &c.], is referred to.

270,609. **Karmazin, J.** March 13, 1926.

Tubes of special section. — The tubular projections of the superposed radiator elements of the type described in Specification 201,934 have tongues *d* pressed out of their bottoms so as to have one or more narrow transverse bars *a*. Perforations *e* may be made in the elements between the tubular projections. Specification 266,913, [Class 83 (ii), Metal articles &c.], also is referred to.

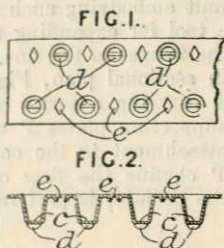

270,891. **Serck Radiators, Ltd., and Serck, O.** April 27, 1926, *Drawings to Specification.*

Honeycomb-tube apparatus. — Tubes for heat exchangers such as motor vehicle and aircraft radiators, oil coolers &c., and of the kind in which the ends are brought into polygonal form in order that adjacent tubes may conveniently be secured together, are formed of elliptical cross-section with an externally projecting longitudinal corrugation at each end of the minor axis. Specifications 208,136, 247,935 and 254,959 are referred to.

271,065. **International General Electric Co., Inc.**, (Assignees of *Allgemeine Electricitäts Ges.*). May 11, 1926, [Convention date].

Drip - interception devices. — Surface condensers having steam spaces *f* are provided with converging baffle plates *g* beneath the nests of pipes *e* to deflect the condensate from the steam paths *m* and direct it on to channels *i* from which it flows through openings *k* on to the pipes traversed by the coldest cooling water.

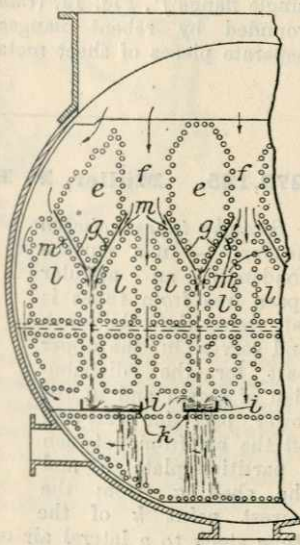

271,122. **Still, W. J.** Nov. 21, 1925.

Gills for tubes. — A tube 1 is provided with heat radiating elements comprising a flattened wire spiral 6 recessed helically by a binding wire 7 wound on the tube along with the spiral. The contacting side of the spiral may be milled to fit the tube and a binding wire of solder may be wound along with the spiral which is subsequently fused to receive the wire; alternatively, the wire may be spot welded in position. The hub itself may be indented to fit the wire.

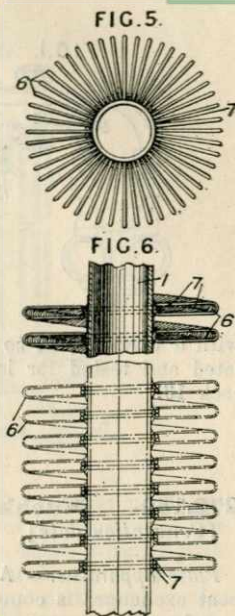

271,461. **Hartmann, P. E.**, (Assignee of *Hartmann, M. & E.*). May 19, 1926, [Convention date].

Plate apparatus. — An air-heater comprises flat-plates *a* spaced apart from one another by being held in the required position between nuts *d* on threaded bolts *c*. The nuts themselves may act as spacers. The forward and rear edges *b* of adjacent plates are bent inwards and welded to form pockets open at the top and bottom, where they are secured to end-plates *i* in suitable slots.

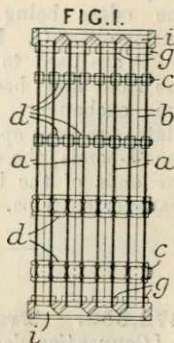

The Specification as open to inspection under Sect. 91 (3) (a) comprises also the provision of reinforcing iron strips *g* at the top and bottom edges and by intermediate longitudinal channel-section strips. This subject-matter does not appear in the Specification as accepted.

271,567. **English, W. E., and Hannan, J. R.** Feb. 26, 1926.

Field-tube apparatus. — In stills having heating means comprising a number of "Field" tubes 3

which project through the still casing 1, the supply and discharge pipes 7, 9 are each provided

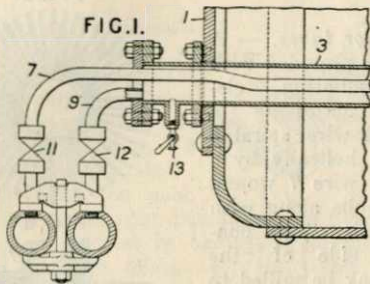

with a valve 11, 12 so that any tube can be isolated and tested for leakage by opening a test-cock 13.

272,152. Muchka, J. June 7, 1926, [Convention date].

Plate apparatus.— A heat exchanger is composed of plate members which can be slid out laterally being loosely connected to one another by U-shaped edge members. In the example plates A constitute the main body of the exchanger, the edges being held by members C. Plates B, D are used to form the front and back of the exchanger. The plates are kept apart by reinforcing bars fitting to the U-bends, the whole being secured by studs on the ends of the bars which engage in holes in transverse strips.

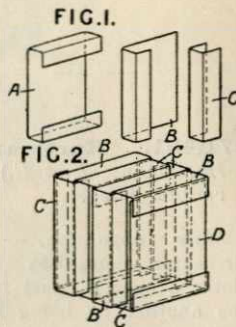

272,852. Trane, R. N. June 21, 1926, [Convention date].

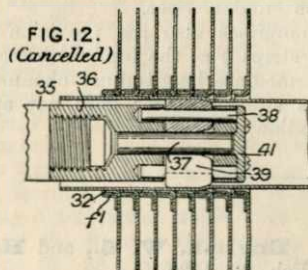

Gills for tubes.—A heat radiating tube is provided with a number of sheet metal fins having

re-bent flanges in contact with the tube to provide reinforcement and good heat contact. A radiator unit embodying such tubes is described, and also a tool for expanding the tubes into contact with the flanges of the fins. The radiator unit U shown in sectional plan, Fig. 1, comprises a bent tube T carrying a series of radiating fins F between supporting plates P which are flanged at 13 for attachment to the casing plates 18. The plates P confine the flow of air over the fins F, and the radiator is preferably placed within a cabinet

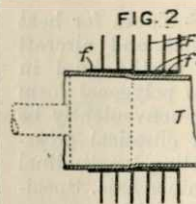
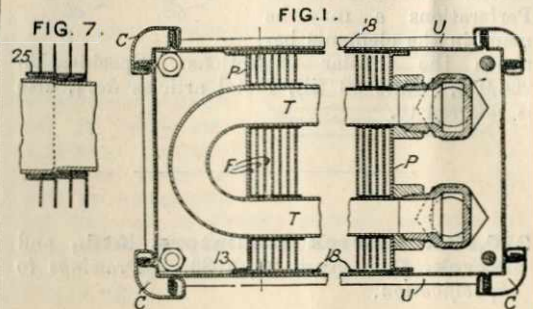

C through which the air flows upwards and is discharged into the room. Each fin F has two spaced openings for the two parts of the tube T, and the openings are formed with re-bent flanges f, Fig. 2. The fins are preferably of copper, 0.010—0.015 inch in thickness, and the tube T is expanded into good contact with the flanges by hydraulic pressure or by an expanding tool. The re-bent flange may enclose a ring 25, Fig. 7, or a single flange f', Fig. 12, (Cancelled), may be surrounded by re-bent flanges 32 formed from separate pieces of sheet metal.

273,125. Müller, P. H. Sept. 28, 1926.

Straight tubes between headers.— In a surface condenser, an annular space free from tubes is left round the tube stack and serves in the upper part for the distribution of steam and in the lower part for carrying off the air from between a partition plate b and the shell a, from the lowest point k of the tube stack to a lateral air outlet i. The shell a

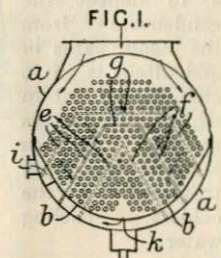



may extend from end to end of the condenser, the tube sheets being suitably secured to the shell. The partition plates in the headers for directing the flow of water may be arranged as shown at *e, f, g*.

273,213. White, A. E., (*Andale Engineering Co.*). March 15, 1927.

Headers; straight tubes between headers. — A casing 2 enclosing a number of tubes 1 joining headers 7, 15, is provided with ducts 19, 20 for one medium, parallel with the casing, so that on fixing a cover 15, the U-shaped conduits 21 connect the ducts with the two groups of tubes 1. A vent 27 is left between the joints around each duct and that around the casing 2.

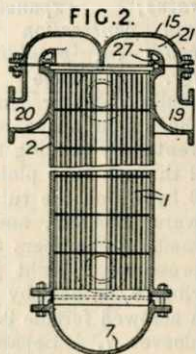

273,262. Akt.-Ges. der Maschinenfabriken Escher, Wyss, et Cie. June 23, 1926, [Convention date].

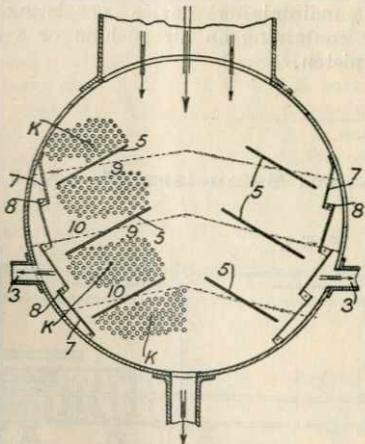

Drip-interception devices. — Drip-plates 5 are so arranged between nests K of tubes as to leave converging tube-free spaces 9 for steam between the upper tubes of a nest and the drip-plate and diverging similar spaces 10 for air &c. between the drip plate and the lower tubes of an adjacent nest. Additional drip plates may be provided, gaps 8 permitting the air &c. to pass to the air-pump suction 3.

273,298. Morterud, E. June 25, 1926, [Convention date].

FIG 1
(Cancelled)

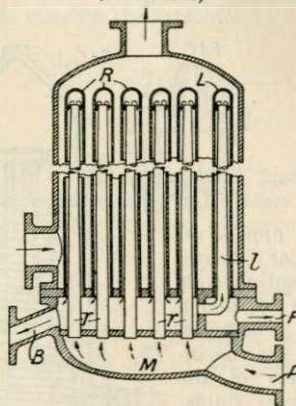

Field-tube apparatus. — The velocity of steam-flow in Field-tube apparatus is increased by arranging one or more of the tubes in series with the remainder R, uncondensed steam from B being re-circulated by a fan, not shown, to the chamber M. In the example steam enters at A, the main condensate outflow is at B while a secondary condensate and air exit is at F. The inner tubes *r, l* may taper from bottom to top.

The Specification as open to inspection under Sect. 91 (3) (a) comprises also an apparatus without the re-circulating device as shown in the figure. This subject-matter does not appear in the Specification as accepted.

273,306. Samesreuther, R. June 22, 1926, [Convention date].

Plate apparatus. — Plates or walls of vessels to be heated or cooled by the passage of fluid through tubes are made by welding the tubes on to one side of the plate or wall. The tubes *b* are welded to the plate or wall *a*, which may consist of cast iron, nickel, copper-nickel bronzes, &c., by fusing wires of similar material thereon by electric or autogenous welding, to produce a layer *c* which preferably covers half of the tubes. The tubes may be in the form of coils, helices, or grates. The tube wall may be subsequently lagged by insulating material *d* held in place by a sheet iron jacket *f*.



273,450. Hillier, H. May 26, 1926.

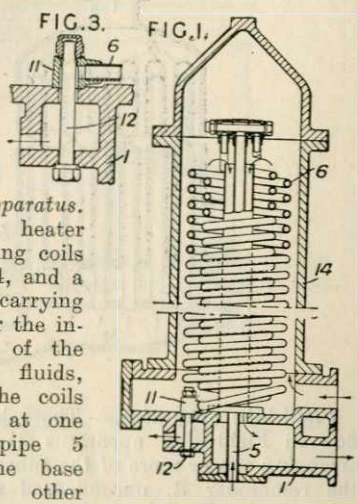

Coil-tube apparatus. — A tubular heater comprises heating coils 6, a casing 14, and a base casting 1 carrying all branches for the ingress or egress of the heat-exchanger fluids, the ends of the coils being secured at one end to a pipe 5 attached to the base and at the other directly to the base by means of hollow connecting pieces 11 permanently secured to the ends of the coils, a bolt 12 passing through the connecting piece and the pipe or base casting. Each connecting piece may be joined to two or more coils. Specifications 2584/99 and 20468/00, [both in Class 123, Steam generators], are referred to.

273,605. Thornycroft & Co., Ltd., J. I., Thornycroft, Sir J. E., and Donaldson, T. Feb. 12, 1926.

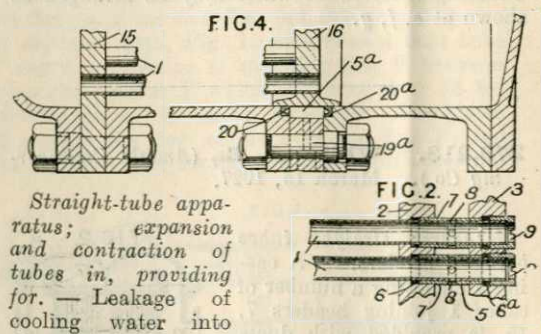

Straight-tube apparatus; expansion and contraction of tubes in, providing for. — Leakage of cooling water into the steam space of a surface condenser is prevented by passing the cooling-water tubes 1, Fig. 2 through tube-plates 2 in front of the tube-plates 3 by which the tubes are secured to the cooling-water headers, and by maintaining the intermediate chambers 5 filled with pure water under pressure. Tight joints are formed by packing rings 6, 6^a held by plain or screwed sleeves 7 and a screwed ferrule 9. Openings 8 are made in the sleeves 7. Separate screwed ferrules may be used in each tube-plate. The tube-plates 2, 3 may be stayed by screw studs. In the case of a condenser in which the cooling-tubes are fixed, as by expansion, in a fixed tube plate 15, Fig. 4 at one end and a sliding plate 16 at the other end, the plate 16 slides over an annular water-chamber 5^a having channelled packing rings 20, 20^a and supplied with pure water through a radial opening 19^a. The chambers 5, 5^a may be supplied with water by a pump acting through a pressure maintaining device consisting of a chamber containing an air cushion or a spring-pressed piston.

273,803. British Thomson-Houston Co., Ltd., and Samuelson, F. April 7, 1926.

Straight tubes between headers; casings. — A feed-heater is constructed with a number of compartments 1, 2, 3 formed in one continuous length and separated by partitions and a series of water tubes 11 extending through all the compartments, steam from independent sources being introduced into the compartments at such temperatures as to heat the feed-water progressively as it passes through the heater. Each compartment may comprise an outer shell 4, 5, 6 secured to adjacent sections. Condensate from one com-

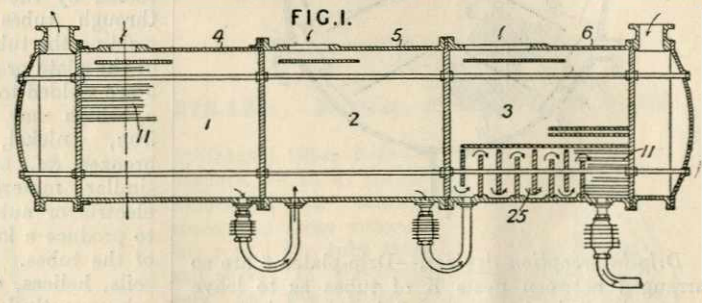

partment is led to the next colder section and in the coldest section 3 it is caused to pass over the feed-water tubes by baffles 25.

273,886. Young, J. W., and Metropolitan-Vickers Electrical Co., Ltd.
June 16, 1926.

FIG. 7.

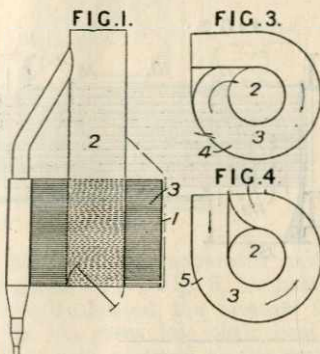
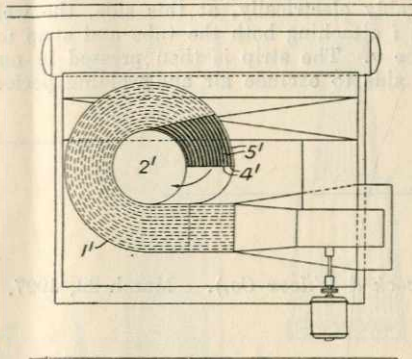
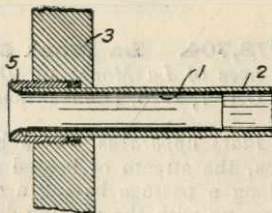

Plate apparatus.—A heat exchanger comprises a substantially cylindrical casing 1 disposed about a central flue 2 and divided by partitions 3 into a series of chambers of substantially annular form alternate ones 4, Fig. 3 of which each communicate with the flue and with a conduit external to the casing, the others 5, Fig. 4, each communicating with fluid inlets and outlets in the outer walls of the casing, the fluids passing through the chambers in a substantially circular path and preferably in counter-current. In a modification, Fig. 7, the series of chambers 4', 5' extend lengthwise of the flue 2' within the casing 1'.

274,629. Yorkshire Copper Works, Ltd., and Fraser, K. June 30, 1926.

Nozzles on tubes for facilitating flow of fluid.—Condenser tubes 2 are fitted at their ends with liners 1 of substantially uniform thickness of metal terminating at their outer ends at or short of the outer



extremity of the ferrule 5 and extending within the tube a distance beyond the inner surface of the tube plate 3. The outer ends of the liner may be flared to bed in a corresponding chamfer of the ferrule or may be flanged over the end of the tube 2 under the ferrule.

275,188. Electrolux, Ltd., (Assignees of *Platen-Munters Refrigerating System Aktiebolag*). July 31, 1926, [Convention date].

FIG. 3. (Cancelled)

FIG. 1.

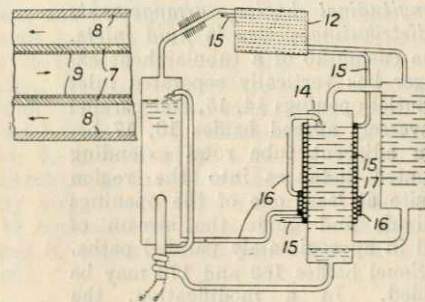
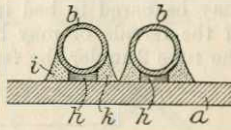

Plate apparatus.—In continuous-cycle absorption refrigerating machines of the type containing a pressure-equalizing inert gas, the pipes conveying the cooling-liquid, e.g. water, are of copper or like material corrosion proof with respect to the cooling-liquid and are arranged in metallic contact with the condenser coil and the wall of the absorber, which are of material, e.g. iron, corrosion proof with respect to the refrigerant. To improve the heat transfer the coils may be embedded in aluminium, zinc or other material. As shown in Fig. 1, the condenser 12 is formed of alternate copper and iron coils in contact and embedded in a cast or other metal jacket, while the absorber 14 has the copper water coil 15 embedded in a casting 17 on its walls. The weak liquor pipe 16 is also preferably embedded in part of the same casting.

The Specification as open to inspection under Sect. 91 (3) (a) comprises also the following subject-matter:—The condenser may be formed of a coil of concentric tubes 7, 8, Fig. 3 (Cancelled), the inner tube conveying the water having a copper lining 9. In this form the surrounding air assists in cooling the outer tube 8. The copper water pipe may be coiled around a groove in a thick iron wall of the absorber. This subject-matter does not appear in the Specification as accepted.

276,013. Samesreuther, R. Aug. 12, 1926, [Convention date]. Addition to 273,306.

Plate apparatus.—In making plates or walls of vessels to be heated or cooled by passage of fluid through tubes, by welding the tubes to one side of the plate or wall as described in



the parent Specification, a strip *h* of copper or other metal of good heat conductivity and of the required shape is placed between the plate &c. *a* and the tube *b* prior to welding. The strip is pressed in from one side of the tube, then welded, preferably electrically, at this side, the welding metal *i* attaching both the tube and strip to the surface *a*. The strip is then pressed in on the other side to exclude air and welding performed at *k*.

276,262. Babcock & Wilcox, Ltd., (Babcock & Wilcox Co.). March 22, 1927.

Longitudinal baffles, arrangements of; distributing plates in fluid inlets.

—The casing 10 of a tubular heat exchanger has vertically separated inlet and outlet openings 14, 15, and parallel transversely spaced baffles 16, 17 between adjacent tube rows extending graduated distances into the region opposite at least one of the openings to divide and guide the stream of liquid in approximately parallel paths. Additional baffles 163 and 173 may be provided. In a modification, the various baffles 163, 173 are made as prolongations of the baffles 16, 17.

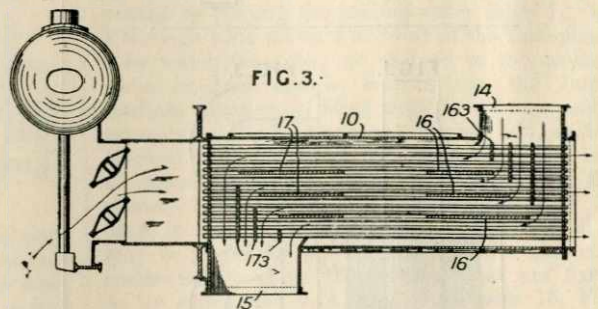

277,556. Serck Radiators, Ltd., (Zimmermann & Co.). Feb. 16, 1927.

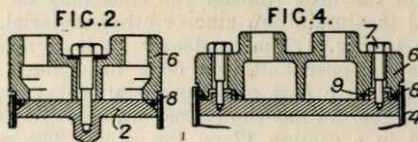

Expansion of tubes, providing for.—The casing 4 of a heat exchanger comprises a tube without flanges or with only one flange, the tight jointing for the tube plates 2 and the end covers 6 being effected by means of screws 7 and a packing 8 pressed against the inside wall of the casing. A second packing ring 9 is shown in Fig. 4, leakage past the ring 8 escaping to the atmosphere from the space between the packings.

sides 3 of which overlap one another, and are secured by soldering. By shaping the sides as

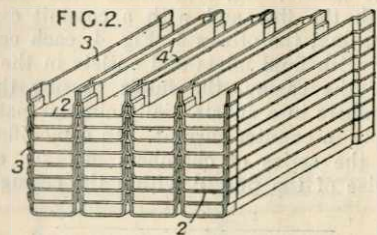

shown the water passages 4 have a double thickness of metal.

278,704. La Mont Corporation, (Assignees of La Mont, W. D., and Ernst, A. F.). Oct. 7, 1926, [Convention date].

Plate apparatus.—In a heat exchange apparatus, the stream of heated or heating fluid flows along a passage having a cross-sectional area so varying with the varying density of the fluid that a velocity at or above the critical velocity of the

277,594. Windhoff, J. A. P. July 18, 1927.

Plate apparatus.—A radiator block comprises rows of superposed channel-shaped units 2, the



fluid is maintained throughout the passage. The tubes 12, Fig. 5, of a steam generator are so spaced as to form flue passages maintaining the heating gases at or above the critical velocity of

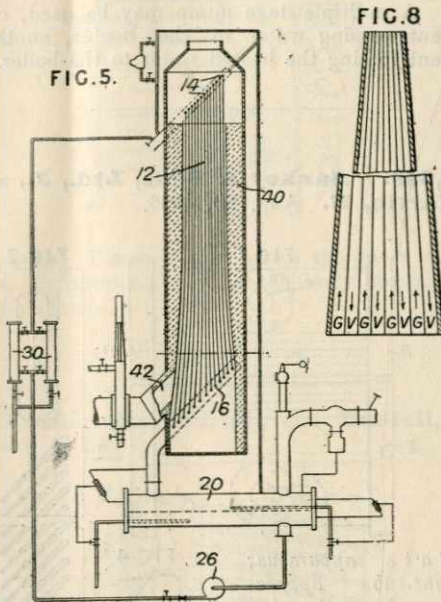

flow. In heat-exchange apparatus having walls forming passages G, V, Fig. 8, for heating gases and vapour to be heated, the passages G become restricted as the gases lose their heat and the passages V become enlarged as the vapour takes up heat.

279,245. **Sadler, P. T., and Sadler, J. H.** Oct. 27, 1926.

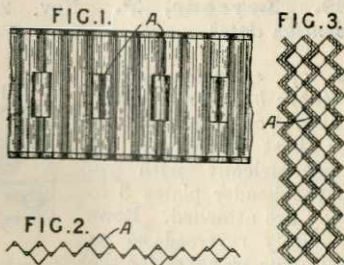

Gills for tubes.—In a radiator wherein each unit comprises a pair of corrugated thin metal plates having their edge seams united to form a corrugated water channel, the units are spaced by a similar corrugated plate which is provided on each side with a number of projections A, formed by reversing the middle portion of the several corrugations, adapted to engage the corrugations of said water channels.

279,446. **Soc. la Precision Moderne**
Oct. 20, 1926, [Convention date].

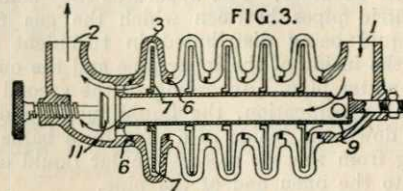
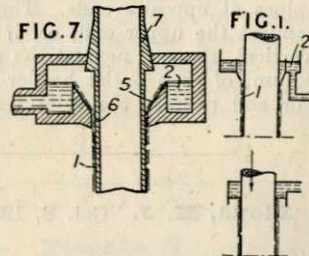

Plate apparatus.—An oil-cooling radiator for motor-car and aircraft engines, and comprising a number of round hollow plate elements 3, Fig. 3, assembled between end branches 1, 2 on a central bolt 7 provided with internal baffles 7 formed of separate sectors placed inside the elements and subsequently welded together. The baffles are loose on the bolt and are provided with bosses to space them from the walls of the elements. Packing rings 6 are provided between the elements, which have round peripheries. The securing bolt may be constituted by a tubular member 9, through which a part of the oil may flow direct under the control of a valve 11 at the delivery end, to vary the cooling. The valve may be controlled by hand, or by a thermostat arranged in a reservoir to which the oil is discharged.

279,526. **Synthetic Ammonia & Nitrates, Ltd., Slade, R. E., Burstall, A. F., and Carey, W. F.** April 30, 1926.



Nozzles and like devices on tubes.—Turbulent thick films of liquid, produced by allowing the liquid to flow by gravity down pipes or surfaces at a rate not less than 300 ccm. per minute per centimetre of periphery of the surface, are employed for exchanging heat between gases and liquids. The liquid supplied to an annular chamber 2, Fig. 1, rises over an annular weir around a pipe 1, and the film becomes turbulent when it reaches a level just below the weir. Gas to be cooled flows upward through the pipe, and partial evaporation of the liquid into the surrounding air facilitates the cooling effect. The weir 5, Fig. 7, may be sloped so that the liquid acquires a velocity normal to the pipe surface, and the chamber 2 may be closed at the top and supported on a tapered sleeve 7 on the pipe 1. The liquid may be supplied to the chamber under

pressure, in which case the film becomes turbulent in the annulus 6, and baffles may be fitted in the weir chamber. The apparatus may comprise concentric pipes between which the gas flows, the liquid being distributed in turbulent films down the inside of the inner pipe and the outside of the outer pipe. According to the second Provisional Specification, the liquid may be distributed down the inside of a pipe by a baffle projecting from the top of the annular liquid chamber into the open end of the pipe.

280,266. Findlay, W. St. John's-
Aug. 5, 1926.

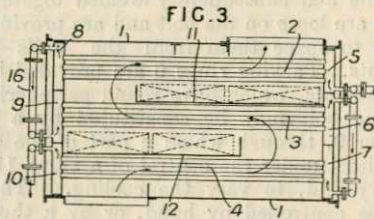

Straight tubes between headers.—A heat-exchanger described in the form of a fuel-economizer for heating feed-water is of the type in which the water or medium to be heated flows through three or more identical banks 2, 3, 4 of straight tubes in series arranged in a common casing 1. The headers or header chambers 5-10 form the end-walls of the casing and are connected by pipes at opposite-ends. These pipes, as at 16, connect the upper end, or, if the tube banks are vertical, the end nearest the outlet for heating medium, of each outlet header with the lower end or end nearest the inlet for heating

medium of the adjacent inlet header, and in each case beyond the tube-bank. When used as an economizer, the heater is mounted above or at the side of the boiler, and mechanical scrapers may work on the baffles 11, 12 to clear them of soot. A multiple-stage pump may be used, one element passing water to the heater, another element forcing the heated water to the boiler.

280,649. Sankey & Sons, Ltd., J., and Martin, N. Aug. 20, 1926.

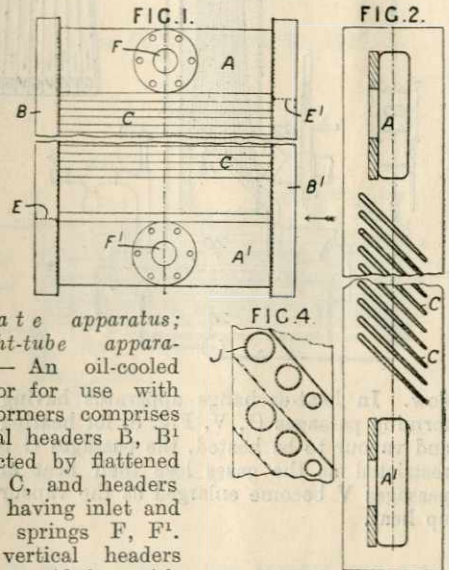
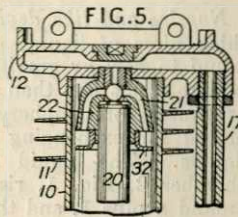

Plate apparatus; straight-tube apparatus.—An oil-cooled radiator for use with transformers comprises vertical headers B, B' connected by flattened tubes C, and headers A, A' having inlet and outlet springs F, F'. The vertical headers are provided with division plates E, E'. In a modification, the flattened tubes are replaced by tubes J, Fig. 4.

280,683. Lloyd, H. J. Oct. 8, 1926.

Straight-tube apparatus having internal baffles.—In a steam-heated radiator for railway vehicles, a circular baffle 32, Fig. 5, is attached to the steam inlet fitting 22 so as to leave a narrow passage between its edge and the wall 10, whereby the steam is directed downwards in close contact with the wall to secure a better exchange of heat. The baffle plate may alternatively be cylindrical, and the passages 21 may be inclined downwards.



281,289. Leveque, P. Nov. 26, 1926,
[Convention date].

Tubes of special section; straight tubes between headers.—The tubes 4 of an economizer or other heat exchanger are placed eccentrically with respect to the header plates 3 to which they are attached. Rows are alternately reversed so as to form sinuous passages for the heating gases. The tubes may have gills 7, which may be rectangular or circular or oval as shown.

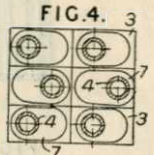

281,819. Hatfield, H. S. Oct. 12, 1926.
No Patent granted (Sealing fee not paid).

Plate apparatus.—One fluid passes through a metal tube A of flat section bent in zig-zag form

to be heated by a second fluid passing around the tube in a zig-zag path, the plane of which is at right-angles to the plane of the zig-zag of

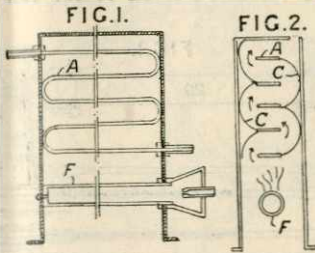

the tube. Plates C may guide the gases or the tube convolutions may be relatively stepped for this purpose.

281,842. Daniell, E., and Daniell, B. Nov. 5, 1926.

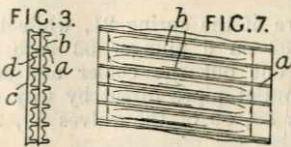

Plate apparatus.—A motor-car radiator comprises water-tube elements each consisting of two metal strips secured together along their edges, one or both of the strips having laterally extending hollow gills *a* with closed ends affording cellular air passages *d*, one or each of the strips being provided with lateral trough-like bulges *b* alternating with the gills *a* and projecting into the air passages so that the whole of the bulge is in contact with the air. Fig. 3 shows elements with one flat side *c*. Both sides may have the gills *a*, with or without a separating flat sheet at the meeting point, of gills on adjacent sheets. The gills may be inclined upwards or downwards from the element, and one sheet of an element may have bulges but no gills.

282,717. Simmen, O. Dec. 28, 1926. [Convention date].



Straight tubes between headers.—Cooling medium is introduced through nozzles 4, 5 into

the larger of tubes 6, 7 extending between headers, thus circulating the medium, which finally escapes at 8. Fluid to be cooled passes in at 2 is reversed in direction by baffles 9 and escapes at 3.

284,338. Soc. Anon. des Etablissements Delaunay-Belleville. Jan. 29, 1927, [Convention date].

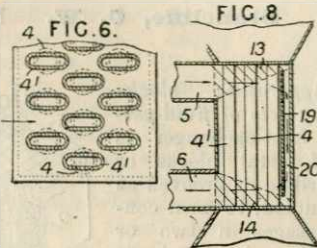

Straight tubes between headers; tubes of special section; longitudinal baffles.—In a heat exchanger comprising a nest of tubes 4 for the passage of one fluid, the other fluid traversing the outer surfaces is flowing from a side inlet 5 to a side exit 6, the section of the tubes adjacent to the inlet and outlet is reduced as at 13, 14 to facilitate the penetration of the fluid among the tubes. The reduction in section may be effected by simple flattening as at 4', Fig. 6, or by bending the side walls inwards or by having tubes with concentric end-sections of smaller diameter. A baffle 19, which may be perforated, may be fitted as shown to form a tube-free fluid-conducting space 20 at the rear of the exchanger.

The Specification as open to inspection under Sect. 91 (3) (a) comprises also the use of the baffle 19 in heat-exchangers which do not employ tubes with reduced end-sections. This subject-matter does not appear in the Specification as accepted.

284,413. Tindale, H. Nov. 1, 1926.

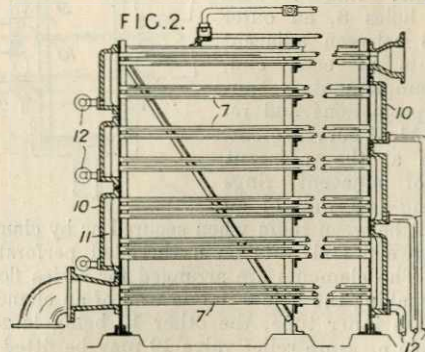

Straight tubes between headers; headers.—Industrial gases such as coal gas or water gas are

passed with a minimum velocity of approximately ten feet per second through a series of tubes 7 subjected to cold or heat in a casing, headers 10 containing ribs or baffles 11 causing turbulence between the passage through sets of tubes. Any condensed fluid is led off separately from each chamber 10 through pipes 12.

285,151. Stancliffe, C. W. Nov. 11, 1926.

Plate apparatus; blocks traversed by sets of fluid-passages.—A heat-exchanger is built up of metal blocks or plates so drilled or grooved as when assembled, to form continuous passages in two or more directions for the heat-exchanging fluids. Fig. 1 shows an assembly of blocks A - C, drilled in two directions, together with suitable header plates D, E; Fig. 7 shows a plate J grooved at top and bottom and traversed by passages K at right-angles to the grooves. When assembled, two sets of passages at right-angles are thus formed, while, in a modification with holes drilled across the thickness of the plate, three such sets of passages are formed on assembly.

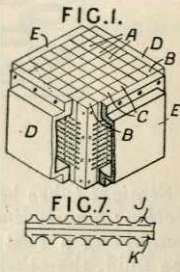

285,524. Potts, C. H. Oct. 8, 1926.

Plate apparatus.—A radiator or cooler comprises a tier of thin hollow metal elements 1 having inlet holes at one end and outlet holes at the other, an inner ring 7 with radial holes 8, an outer ring 6 between adjacent elements at each end, and complementary annular projections and recesses 11 of curved cross-section at the adjacent faces of adjacent rings engaging one wall of an element between them when secured as by clamping between end nuts on a threaded perforated pipe. The elements are arranged for series flow, as by making the hole 9 in one wall of an element to fit the inner tube, the other 10 being larger. A simple pressure relief valve 19 may be fitted to allow fluid to bye-pass the cooler through a tube 20, Fig. 1. In a modification, Fig. 6, the right-hand connection serves as inlet and a squared rod

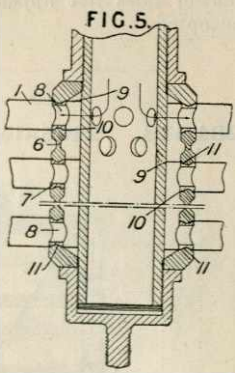

25 attached to a pressure-relief valve 19 extends through the bye-pass tube 20 and bears in a sleeve 26 secured to the cut-out valve 24. Under undue pressure the valve is moved to the left against

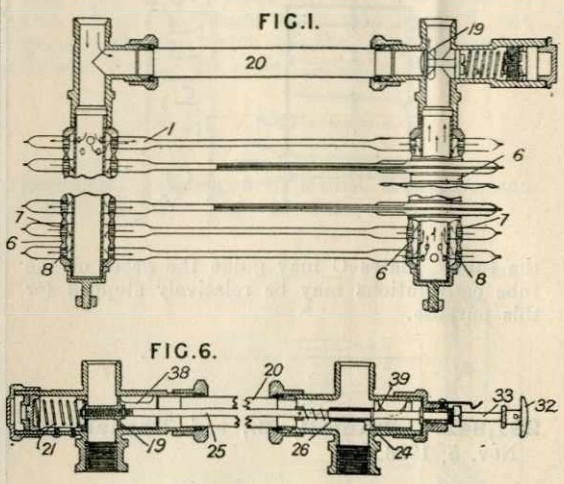

the pressure of the spring 21, while by pressing the knob 32 on a plunger 33 both valves are moved to cut out the cooler and connect the inlet and outlet pipes direct by way of the cut-away parts 38, 39 of the valves 19, 24 and the tube 20.

286,682. Superheater Co., (Assignees of Armacost, W. H.). March 9, 1927, [Convention date].

Tubes of special section.—A series of heat-exchanging elements 3 having intermediate portions having passages for fluid occupying a greater space transversely than in another direction, and capable of resisting high internal pressure without distortion, for example a parallel series of tubes, are mounted in a passage 1 and, according to their position about their longitudinal axes, determine the free flow area through the passage. Thus, with the elements in the position shown, the free-flow area is at a minimum. If each were twisted through 90°, the free-flow area would be a maximum. The elements may be fixed as shown in U-bends 8 in glands 9 or may be expanded into tube plates at the desired angle. Specifications 6304/15 and 100,223, [both in Class 83 (i), Metal articles &c.], are referred to.

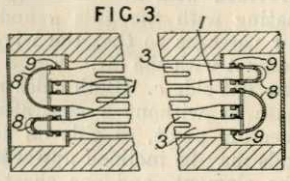



286,757. Stancliffe, C. W. Nov. 12, 1926.

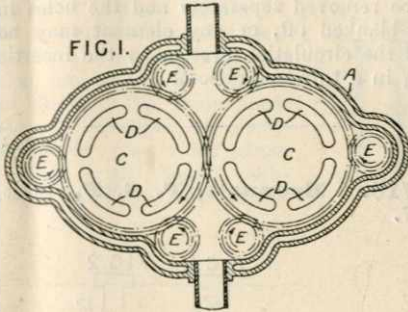
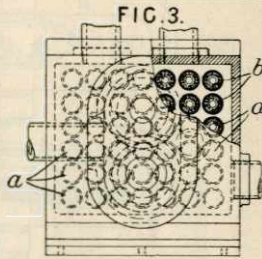
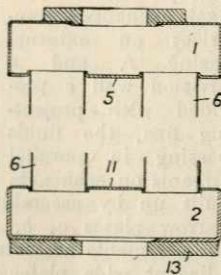

Plate apparatus; straight-tube apparatus with internal baffles.—Heat-transfer apparatus comprises a heated container, through which passes the fluid to be treated, provided with a series of wipers for wiping substantially continuously the internal surface of the container in contact with the fluid, the arrangement being such that small volumes of fluid separated by the wipers are brought into contact with the heated surface of the container one after the other. Fig. 1 shows a pump of the gear type with heated casing A and gear-wheels C, which may have heating passages D and idler wheels E, the small volumes of fluid between the gear teeth being heated by contact with the casing. In Fig. 3 the fluid is forced by a separate pump through tubes a externally heated. Ribbed rotors b turn within the tubes, the fluid to be heated being continuously moved over the inner surface of the tubes in the spaces between the ribs. In a modification (Figs. 6 and 7 not shown), the tubes are circumferentially ribbed internally and the rotors have spring-pressed blades extending between the ribs. Reciprocating moving parts may be used.



287,624. British Thomson-Houston Co., Ltd., and Dumas, R. Dec. 22, 1926.

Headers.—In a radiator for electric transformer tanks, and comprising upper and lower headers 1, 2 connected by tubes 6, each header is constructed from a suitably shaped plate, the sides being bent or pressed up to box-like form with the corners arc-welded. The tube plate 5, 11 is secured to



the sides of the header. A metal flange of relatively thick material may be secured to the bottom plate of the lower header.

287,777. Chavara, M., and Churruca, I. Aug. 19, 1927.

Gills for tubes.—The walls of the vertical water ways of a radiator are deeply corrugated as at B to receive thin flat gill-plates C which are clinched therein and extend across the air space. The folds are then bent upwards or downwards, Fig. 9, for their whole length, or in some cases bent at the front and back edges of the radiator in a direction opposite to that in which they are bent in the intermediate parts. The thickness of the gill-plate may be from one tenth to half a millimetre.

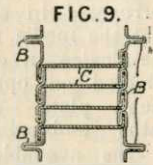
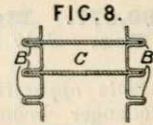

289,320. Büchner, W. Sept. 2, 1927.
Drawings to Specification.

Gills for tubes.—Detachable groups of radiator tubes of thin flattened section set edge-on to the direction of the air current are fitted with radiating gills in the form of separate plates threaded over the tubes and shaped to space the gills apart. These parts are not connected with the tubes and may thus be of aluminium or other good conducting material not adapted for soldering.

289,661. Sacchi, M. Casale. June 7, 1927.

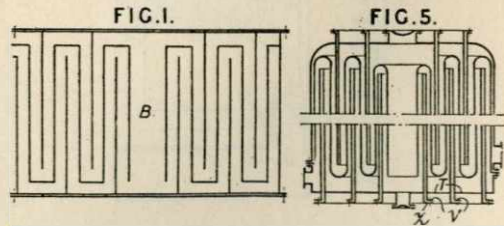
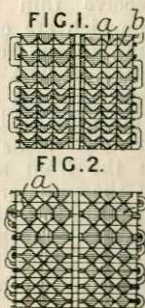

Plate apparatus is constructed with independent and easily separable parts so arranged that each element is free to expand without straining the joints or the adjacent parts. The space B, Fig. 1, may contain or be surrounded by an electric

or other heating element. Fig. 5 shows a modification composed of separate elements each comprising two cylindrical walls connected at one end by a plate T. The elements are bolted together through the flanges *v*, *z*, which are actuated outside the bolted portion of the apparatus. Specification 252,713, [Class 1 (i), Chemical processes &c.], is referred to.

289,677. Menzel, E., and Menzel Akt.-Ges. July 14, 1927.

Plate apparatus. — A heat-exchanger comprises stacks of superimposed plates corrugated in such a manner that the media flowing through the device in contra flow are directed on opposite sides of each plate in serpentine paths embracing the whole of the available area of the plates. The plates *a* may be superimposed regularly as in Fig. 1, the paths of the fluids being defined by partitions *b* or alternate plates may be inserted as in Fig. 2. no partitions being then necessary. The corrugations may be angular or curved and the paths of the fluids may be spiral, concentric or zig-zag, and either single or double in each section.



289,698. Morra, M. Sept. 16, 1927.

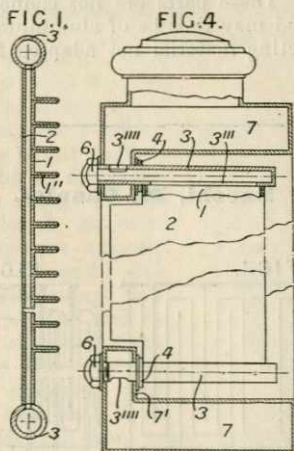
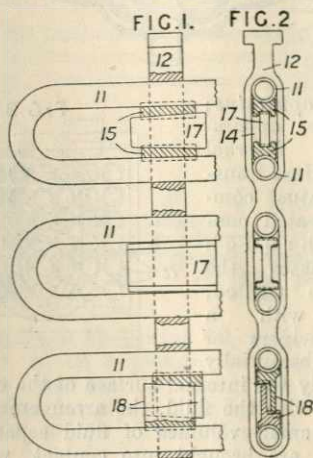

Plate apparatus. — Detachable elements consisting of sheets 1, 2, one or both of which is ribbed by folding as at 1¹, are connected to the main tanks 7 through tubular collectors 3 extending to one side within extensions 7¹ of the tanks 7, and being held thereto by cap-nuts 6

and collars 4. Apertures 3¹¹¹, 3¹¹¹ allow the circulation of the cooling-water. The elements may be removed separately and the holes in the tanks blanked off, or any element may be cut out of the circulation system by the insertion of a plug in a tubular collector 3.

289,715. Evennett, F. C. F. Oct. 25, 1927.



Tube supports.—The U-tubes 11 of a superheater, feedwater heater, or like apparatus are supported in longitudinal apertures 14 in a sling 12, the tubes being secured in the apertures by wedges. The wedges 17 may bear directly against the legs of the U-tubes or they may engage in grooves in blocks 15 bearing against the legs. A wedge may consist of two members 18 engaging with each other and bearing against the legs of a tube. Two U-tubes may be inserted in the same aperture and secured by a single wedge which is inserted between the tubes, the legs of the tubes being spaced apart by distance pieces.

289,912. Stancliffe, C. W. Jan. 6, 1927.

Plate apparatus: gills for tubes. — A heat exchanger comprises an external casing A and a division wall *e* provided with projecting fins, the fluids passing in parallel

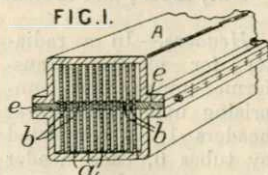

streams on each side of the wall, the wall being built up by assembling a series of wide and narrow plates *a*, *b*. In a modification three compartments are formed by assembling between adjacent wide plates two parallel narrow strips in place of one as shown.

290,471. **Karmazin, J.** July 26, 1927.

Tubes of special section.—A series of heat-exchanger tubes is formed by the nesting together of tubular projections 13 formed on metal sheets. The projections are coned at two angles 13^a, 13^b, the annulus in the wider cone being filled with solder 40. Specification 201,934 is referred to.

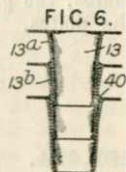

290,812. **Johnsen, E. A.** April 30, 1927.

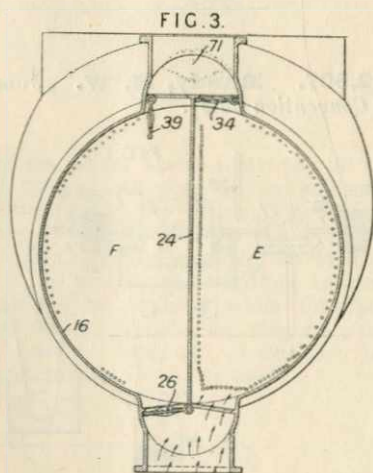
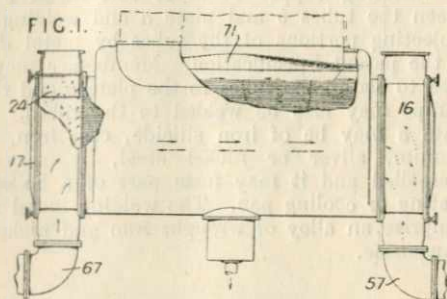

Headers.—In a surface condenser having headers 16, 17 to which cooling water is supplied through pipes 57, 67 in a constant direction, the flow of water through the banks of tubes F, E is reversed by orientation of flap valves 26, 34, 39 governing the flow of water to or from the compartments formed by dividing the headers by partitions 24. Modifications are described for multi-pass condensers, and for condensers to which the cooling water is supplied by several pumps. A curved baffle plate 71 directs the flow of vapour to the cooler parts of the tubes.

290,868. **Berlin, D. W.** Aug. 18, 1927.

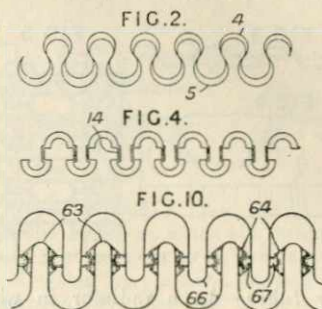

Plate apparatus.—Heaters or coolers having corrugated walls, adapted to be inter-engaged so as to constitute passages for the medium and having self-locking means, are assembled by springing opposing corrugations into one another or by sliding endwise, the locking means preventing opening under internal pressure. Means may be provided for preventing collapse under external pressure. Fig. 2 shows simple corrugated plates 4, 5 inter-engaged, and Fig. 4 shows plates with engaged channel-section parts 14. In Fig. 10 engaging parts 64, 67 are formed on the corrugated plates, which may also have bosses 63, 66 to support the walls against external pressure.

291,593. **Macpherson, M. C.** May 13, 1927.

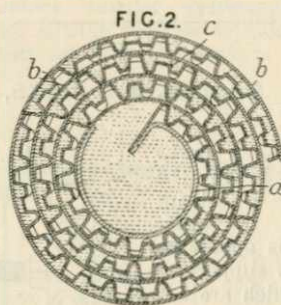
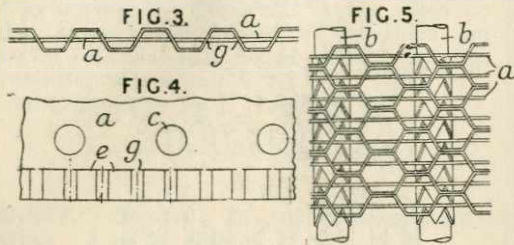

Plate apparatus.—A heat-exchanger is constructed by wrapping an elongated cell, made from two plates b, c one or more of which is corrugated transversely, about a split pipe a, the inner ends of the plates being connected to the sides of the aperture in the pipe. The outer ends of the sheet may be similarly connected to a split pipe or a pipe-like termination may be formed by bending over the end of one plate.

292,041. Soc. Anon. des Usines J. Gallay. Sept. 28, 1927, [Convention date].



Gills for tubes.—In a radiator in which flat gill plates *a* are provided with holes *c* through which the tubes *b* pass and with shaped front or back edges to present a honeycomb appearance, such shaped parts are separated from the main plate by a series of slits *e* so that after shaping the honeycomb is only attached to the plate at the mid-point *e* of the inclined sides.

292,258. Parsons, Sir C. A. March 18, 1927.

Headers.—The cross-sectional area of the inlet water duct *b* of a surface condenser is increased until comparable with that of the header *c* to decrease turbulence. Baffles *f* may also be used or a screen as described in Specification 258,912.

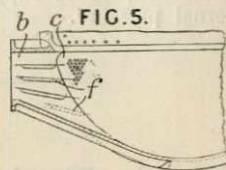

292,343. Sugden, T. June 8, 1927.

Headers.—A partition plate *L* in the header of a steam superheater or other like tubulous apparatus is bolted to supporting pieces *D* which are adjustably secured against the walls of the header. The supporting pieces are forced and held against opposite header walls by a bolt having a head *J* pressing against one piece and carrying a nut *K* pressing against the other piece. The partition is formed of two plates which may be so recessed at their meeting edges

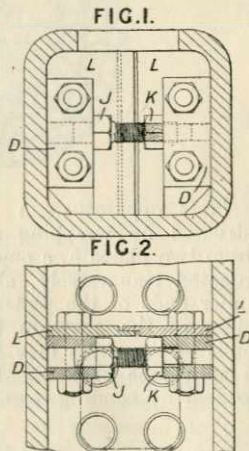

that they overlap, or instead of overlapping, a gap may be left between the inner edges of the plates, the gap being closed by a strap bolted to the plates.

292,484. Samesreuther, R. June 16, 1927, [Convention date]. Addition to 273,306.

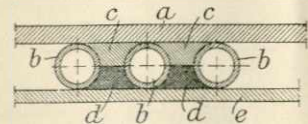

Materials for making.—The apparatus is made by inserting copper or other soft metal *c* between the tubes *b* and plate *a* and welding the projecting portions of the tubes by metal *d*, as in the parent Specification. Members *e* may be used to clamp the tubes to the plate *a* and these clamps may also be welded to the tubes. The plate *a* may be of iron silicide, cast iron, aluminium, silver or nickel steel, it may be enamelled and it may form part of a boiler or heating or cooling pan. The welding metal may comprise an alloy of wrought iron and nickel or manganese.

292,507. Bundy, H. W. June 20, 1927, [Convention date].

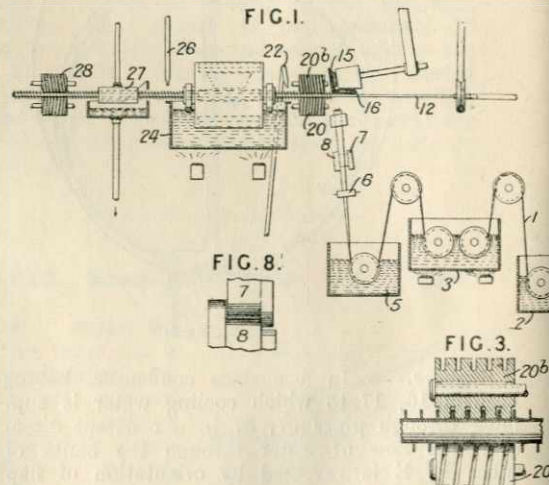

Tubes, cross-sections of.—A metal tube with a spiral fin useful for the transference of heat is formed from strip stock, Fig. 1, which may be previously tinned, or be drawn through an acid bath 2, a solder bath 3, and a cooling water bath 5. The stock 1 is then drawn over a guide roller 6, and between rolls 7, 8, Figs. 1 and 8, which



gives it an angular configuration, after which it is coiled on a spinning arbor 12, the fin portion being crimped by co-operating rolls 15, 16. Rollers such as 20, 20^b in the form of spirals then shape the tube, as shown in Fig. 3. Acid is then supplied by a spray 22, and the tube given a coating of solder from a bath 24, excess being blown off by a nozzle 26. The tube is cooled by a bath 27 and then passes through rollers 28 which serve to draw the tube along. The convolutions may overlap, as shown, to form a double-walled tube, or may overlap just sufficient to secure them together.

294,687. Heenan, J. N. D. April 28, 1927.

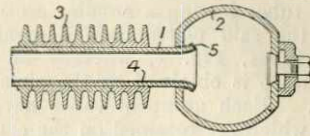

Tubes, cross-sections of. — For a heat-exchanger, a tube 1 has an extended outer surface, such as rings 3 shrunk on to it, and a non-corrosive lining 4 which may extend beyond the tube 1 and be flanged over the end to be gripped as shown at 5 when the tube is expanded into the header 2.

293,759. Leveque, P., (Assignee of Challe, B.). July 11, 1927, [Convention date].

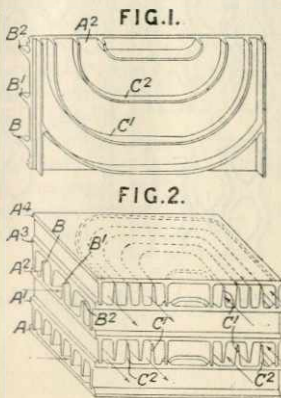
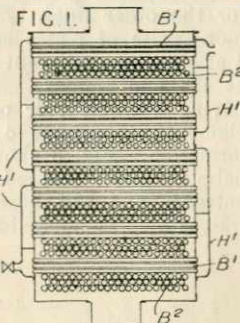

Plate apparatus.—Cast metal plates A, A' - A⁴ have fins fitting into slots on an adjacent plate forming channels into which project fins B, B', B² and C', C² formed on one or both sides of the plates. In the examples shown the fins B, B', B² are straight and might be in contact with combustion products while the fins C', C² are curved and the channel may be used for air to be heated. Both sets of fins may be straight and set parallel or at any angle.

294,836. Power-Gas Corporation, Ltd., and Rambush, N. E. Dec. 19, 1927.

Straight tubes between headers. — A heat-exchanger comprises a number of juxtaposed layers of nests B¹, B² of horizontal tubes, each nest being transversely placed with respect to adjacent nests. Alternate nests are connected at their ends by independent, easily removable casings H in such a manner as to form independent tubular systems, provision being made for cutting out one or more systems while the others are still in operation.



295,029. Aktiebolaget Ljungströms Angturbin. Aug. 4, 1927, [Convention date].

Plate apparatus; tubes, cross-sections of; gills for tubes. — In an air-cooled steam condenser comprising a series of flat tubes 1, 2, 3 which are collected in groups, some or all of said tubes are provided on the outside with corrugated &c. plates 11 which are soldered or otherwise secured to the flat surfaces thereof, the plates between two tubes of the same group being secured to both tubes. The plates 13 on the outside of the outer

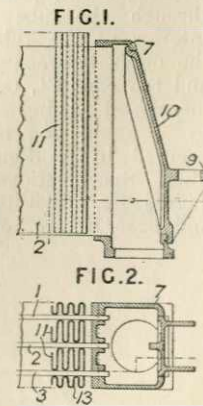

294,518. Crane Packing, Ltd., and Wilkinson, F. C. W. April 25, 1927.

Nozzles on tubes.—A condenser tube end-fitting or ferrule has an outwardly flared end 4 and an inward shoulder 5 to prevent undue movement of the tube 2 behind which a series of holes 6 is drilled to prevent eddying in the inward stream of water. Specification 248,713 is referred to.

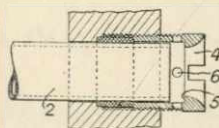

tubes 1, 3 are adapted to be about one-half the height of the plates 11, or alternatively the plates 13 are dispensed with and the said tubes are replaced by tubes having a smaller sectional area, while all the said plates have a greater height than the tubes, Fig. 1, whereby an increased cooling surface is obtained on the air side of the condenser. Each group of tubes have separate headers 7 which are retained on the common distributing and collecting pipes by bolts passing

through lugs 9 on the header covers 10 which are soldered in position.

The Specification as open to inspection under Sect. 91 (3) (a) comprises also tubes wherein the plates therebetween are secured to one only of the tubes, and wherein two plates are interposed between a pair of tubes, one plate being secured to each tube. This subject-matter does not appear in the Specification as accepted.

295,106. Howden & Co., Ltd., J., and Hume, J. H. June 22, 1927.

Plate apparatus.—An air-heater is of the type employing assembled pairs of corrugated plates 1 of which the ridges 2 on each plate of a pair are secured together forming ducts 3 for one fluid, adjacent pairs forming sinuous passages 5 for the other fluid. Elements comprise one or more pairs of plates secured to channel frames 4 at the ends, adjacent elements being connected at the end frames. Fig. 1 shows elements having a single pair of plates. Fig. 2 shows elements, the frame 4 of which are of sinuous formation. Fig. 3 shows elements having three pairs of plates secured to each end-frame. The entrance and exit boxes connected to the end-frames may be subdivided and valve-controlled to

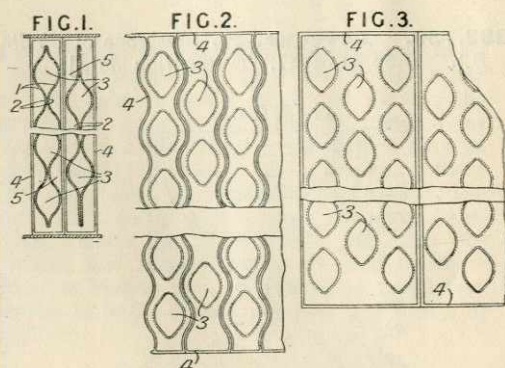

give any desired number of passes through the element.

295,245. Royles, Ltd., and Royle, A. G. May 6, 1927.

Concentric-tube apparatus.—Inner and outer tubes a^2 , a^1 secured at one end in a cap b and at the other in caps C^1 , C provide two passages, one through the tube h to the interior of the tube a^2 and the other between the tubes and the caps C^1 , C , the last-mentioned being prolonged by a spiral rod or rods d secured in position by tinning. Specifications 4690/84, [Class 32, Distilling &c.], and 6285/10 are referred to.

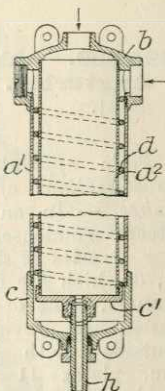

296,605. Hughes, A. E. Dec. 15, 1927.

Nozzles on tubes.—The lower collar e of a detachable radiator-tube is provided with a small-bore hole m restricting the passage of water to effect a more even distribution amongst the tubes of the stack. In modifications, the restriction is formed by shaping-in the end of the tube itself or by fitting a separate coned washer.

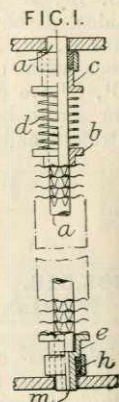



297,509. **Robson, S.** June 28, 1927.

Casings; tube-plates; straight tubes between headers; distributing partitions in fluid inlets and outlets.—In a tubular heat-exchanger the shell A is provided with one or more expansion flanges B connected by rings C and the header plates D or the end covers F are dished to collect trapped liquid or condensate for easy removal, for example through the pipes G. The pipes J, K conveying fluid to the shell A may be furnished, at their points of communication with the shell, with extended trunks or chambers J', K' embracing a part of the circumference, and covering a series of apertures entering the shell.

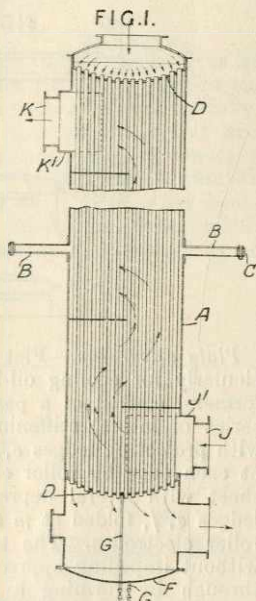

297,589. **Seligman, R.** Nov. 3, 1927.

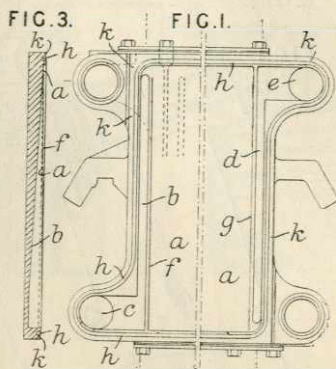
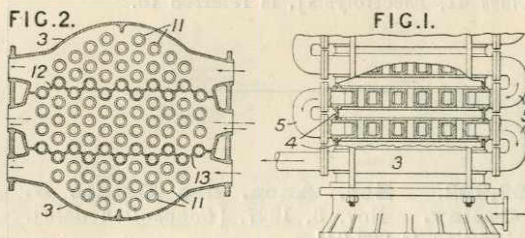

Plate apparatus.—The plates a of heat-exchanger of the general type set forth in Specifications 223,033 and 225,109 are provided with distributing and collecting grooves b, d which are shallower the further they extend from the inlet and outlet ports c, e. At the ends of each groove a rib f, g may be arranged the height of which tapers off with the shallowing of the groove. Another feature comprises the provision of the side K of each packing groove h of less height than the other to allow for accommodation of inequalities in packing.

297,643. **Heizmann, J.** March 7, 1928.

Plate apparatus.—A columnar heat-exchanger comprises alternate heat-exchange elements 3 and separating rings 4. Each element consists of a flat box traversed by short tubes 11 and divided by partitions 12, 13. The elements are connected by external bends 5 and these are formed with branches so as to cause series or parallel flow through the elements or the portions of the elements formed by the partitions. Specifications 17978/01 and 22560/03 are referred to.



299,085. **Cave, T. R. Cave-Browne.** July 21, 1927.

Straight tubes between headers.—A heat exchanger, such as a boiler heated by waste gases, contains a group of vertical or inclined heating tubes 1 which decrease in cross-sectional area in the direction of flow of the heating gases and which are surrounded by a partition 2 extending

to nearly the ends of the tubes. Each tube may be expanded near its smaller end to the same size as its larger end. Tubes having hexagonal ends are connected together and to the tube-plates by brazing or welding. A baffle 15 extending downwards from the top tube-plate prevents water from passing with the steam into the outlet pipe 12.

(For Figure see next page).

299,085.

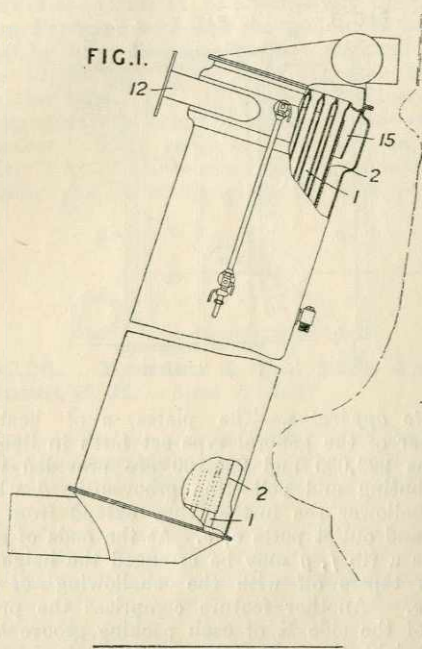

299,100. **Martin, F. G., and Ramsay, W.** April 22, 1927. *Drawings to Specification.*

Materials for making.—Heat-exchanger tubes of non-ferrous metal are coated internally or internally and externally with a uniform electrolytic deposit of chromium. Specification 299,071, [Class 41, Electrolysis], is referred to.

299,892. **Soc. Anon. des Usines J. Gallay.** Nov. 3, 1927, [Convention date]. *Addition to 292,041.*

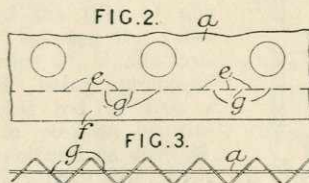

*Gills for tubes of motor-car and like radiators constructed according to the parent Specification with slits *e* leaving metal connecting-pieces *g* retaining a strip *f* of metal at one or both edges of the gill *a*, has this strip bent to any non-hexagonal form. A curvilinear shape is also described. When assembled the front of the radiator has a honeycomb appearance.*

299,998. **Ferranti, S. Z. de, Turner, J., and Ferranti, Ltd.** Oct. 22, 1927.

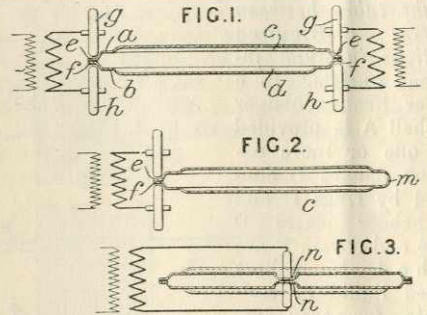
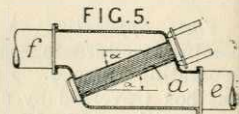

Plate apparatus.—Flat tubes for radiators, particularly for cooling oil-immersed electric transformers, consist of a pair of sheets *a, b* with a series of lateral stiffening depressions *c, d* and with projecting ledges *e, f* simultaneously welded at each edge by roller electrodes; or of a single sheet with lateral depressions *c* and projecting ledges *e, f*, folded at *m* and the edges welded by roller electrodes. The tubes may be reinforced without impeding appreciably the passage there-through by forming a series of abutting depressions *n* in the parts, which may be spot welded, riveted, or otherwise secured together.

300,543. **Akt.-Ges. Brown, Boveri, et Cie.** Nov. 14, 1927, [Convention date].

Straight tubes between headers.—In a heater or cooler, the tubes *a* lie with their longitudinal axes at an angle, α of less than 45° to the axis of the inlet and outlet tubes *e, f* for the other medium.



301,291. **Akt.-Ges. Brown, Boveri, et Cie.** April 14, 1928, [Convention date].

Tube supports.—Where straight tubes *a* in a heat-exchanger pass through the holes *c* in a transverse plate *b* supporting the tubes between the end tube-plates, they are flattened slightly to bring their sides into actual contact with the sides of the holes.

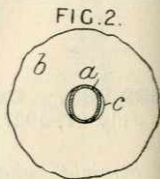



301,426. Aktiebolaget Svenska Järnvägsverkstäderna. Nov. 29, 1927, [Convention date]. Void [Published under Sect. 91 of the Acts].

Coil-tube and plate apparatus.—One of the heat-exchanging fluids passes through a tube or tubes 5 of substantially flat section curved spirally or helically so that the axis of the spiral &c. is parallel to the flat sides. Fig. 1 shows two spirally wound tubes, Fig. 3 shows a number of helically wound tubes *an*. The other heat-exchanging fluid passes around the tubes within a casing such as *f* which may be traversed by heating flues 4.

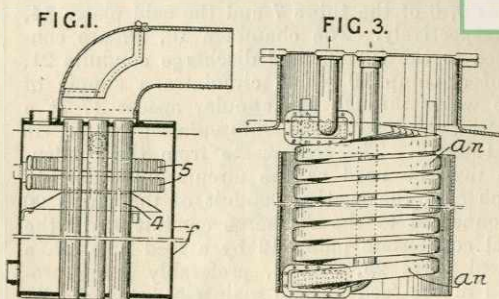

301,453. Lafeuille, F. Nov. 30, 1927, [Convention date].

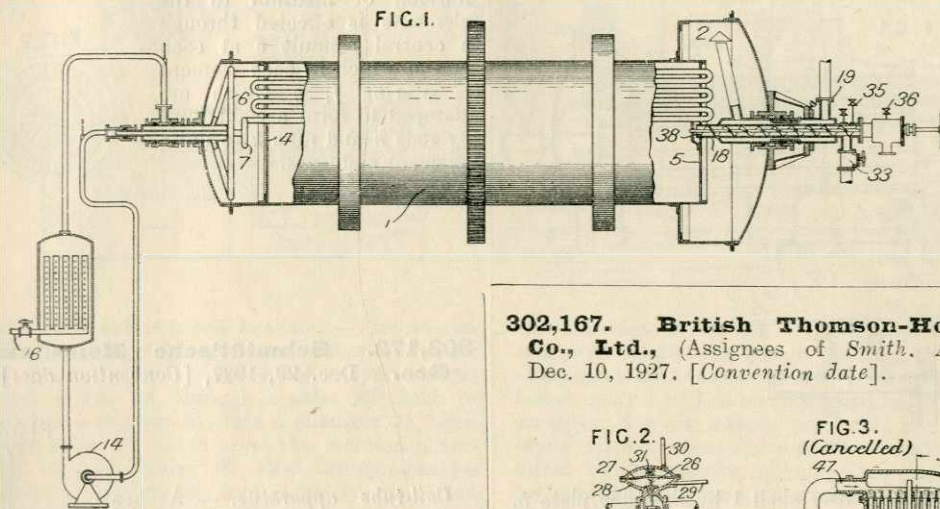

Serpentine-tube apparatus.—A tubular rotary crystallizer comprises a cylindrical casing 1 within which a substantially jointless heating system is provided consisting of pipes arranged in groups between stay plates 4, 5, the apertures of the inlet tubes being led to a crown 6 and the outlets to a crown 7. The convolutions of the pipes are arranged in spiral or other curves and the joints with the elbow pieces at the ends are made by welding. Hot water is circulated through these pipes by a pump 14, steam being led into the heating-system through a pipe 16. Masse-cuite enters through a stationary pipe 18 in which a screw 38 connected with the rotating casing 1 is situated, the passage of the masse-cuite into the casing being assisted by a vacuum maintained in a chamber 2, the vacuum intake being through a pipe 19. Syrup may be introduced through a valve 33, valves 35, 36 serving to clean the pipes by means of a steam jet. Specifications 245,114 and 252,686, [both in Class 32, Distilling &c.], are referred to.

302,167. British Thomson-Houston Co., Ltd., (Assignees of Smith, A. R.). Dec. 10, 1927, [Convention date].

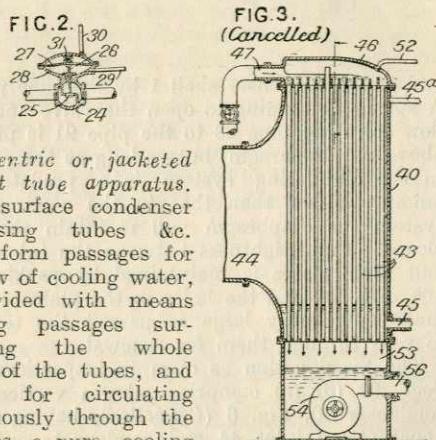

Concentric or jacketed straight tube apparatus.

— A surface condenser comprising plates tubes &c. which form passages for the flow of cooling water, is provided with means defining passages surrounding the whole length of the tubes, and means for circulating continuously through the passages a pure cooling fluid under pressure higher than the pressure in the tubes so that should rupture occur in any of the tubes the leakage will be of condensate or steam into the cooling water and not vice versa. In the condenser shown in Fig. 1, the tubes 7 are surrounded by additional tubes 16, which are connected to tube plates 14, 15 and provide annular spaces 17

which lead to chambers 19, 18 formed by the plates 5, 6 of the tubes 7 and the said plates 14, 15 respectively. The chambers 19, 18 are connected to the suction and discharge conduits 21, 22 of a pump 20 which circulates a supply of pure water through the annular spaces 17 at a ser may be used as the circulating water, in the tubes 7. The condensate from the condensate may be used as the circulating water, in which case the suction conduit of the pump 20 is connected to the discharge conduit 13 of the usual condensate pump 12 by a feed pipe 23, a control valve 25, Fig. 2, preferably being provided in the feed pipe to maintain automatically the circulating system sufficiently full of water and consequently the pressure therein. This valve is housed in a casing 24 and is provided with a stem 26 connected to a flexible diaphragm 27 arranged in a casing 28, and the underside of the diaphragm is connected by a pipe 29 to the conduit 21 while the upper side is connected by a pipe 30 to the chamber formed at the left hand

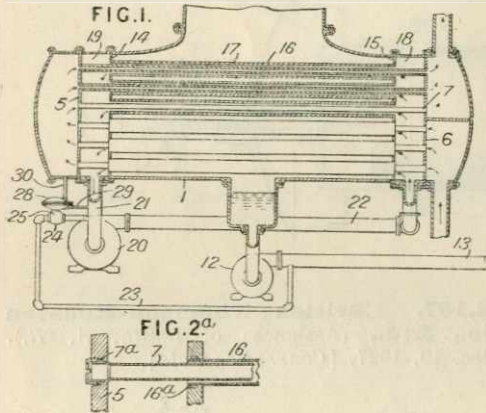

end of the condenser shell 1 by the tube plate 5. A spring 31 tending to open the valve and allow flow from the pipe 23 to the pipe 21 is provided above the diaphragm, but as long as the pressure in the circulating system is a predetermined amount higher than that in the cooling water system the diaphragm will maintain the valve closed. Fluid-tightness between the tubes 7, 16 and their plates is maintained by packings 7^a, 16^a, Fig. 2^a, and the holes in the plates 5, 6 are made sufficiently large to permit the tubes 16 to pass through them for renewal.

The Specification as open to inspection under Sect. 91 (3) (a) comprises also a vertical tube condenser 40, Fig. 3 (*Cancelled*), having an exhaust steam inlet 44 and condensate outlet 45 and a cooling water inlet and outlet 47, 56 respectively. A vacuum is maintained in the tubes 43 as low as or lower than that in space surrounding the tubes by a pump 54 which removes the cooling water and by an air pump which is connected to a pipe 52 leading to the cooling water inlet chamber. Air may be withdrawn from the condenser shell through pipe 45^a, while

the cooling water inlet and outlet chambers 46, 53 are adapted to be connected so that the vacua therein may be equalized. This subject-matter does not appear in the Specification as accepted.

302,562. Kochs & Co., Ltd., W. E.,
(Föge, H.). July 21, 1928.

Plate apparatus.—A heating &c. unit comprises a series of elements *b* of annular cellular formation, the parts being connected by hollow ribs *c*. Heat transmitting fins *d* may be provided. The ribs may rise toward the centre to facilitate disengagement of gases. Admission of medium to the elements is effected through a central conduit *e* at each end of which in each element is a ring *f, g* which are clamped to form a tight joint by rods *h* and nuts *k* to unite adjacent elements.

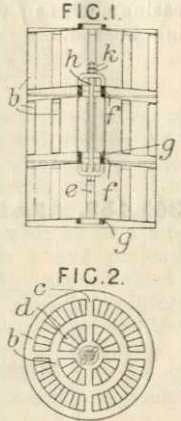

303,172. Schmidt'sche Heissdampf-Ges. Dec. 29, 1927, [*Convention date*].

Coil-tube apparatus.—A heat-exchanger comprises a series of elements each consisting of two or more tubes connected in parallel, each tube being formed for part of its length as a helical coil of small diameter in relation to the diameter of the tube and assembled with the coils end to end so that they form a compound uni-axial coil subdivided into lengths to correspond with the number of tubes of the individual elements.

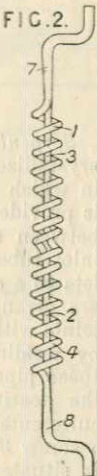

304,183. Kuhlerfabrik Langerer & Reich Akt.-Ges. Jan. 16, 1928, [Convention date].

Plate apparatus.—Channelled plates *b, c* forming water passages are assembled with other channelled plates *d, e* forming air passages, there being on each of the plates corrugations or depressions *h*, for engaging these on adjacent plates to ensure correct positioning.

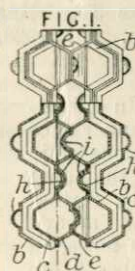

304,269. Wade, H., (Silica Gel Corporation). July 12, 1927. Divided on 304,251. [Class 1 (i), Chemical processes &c.].

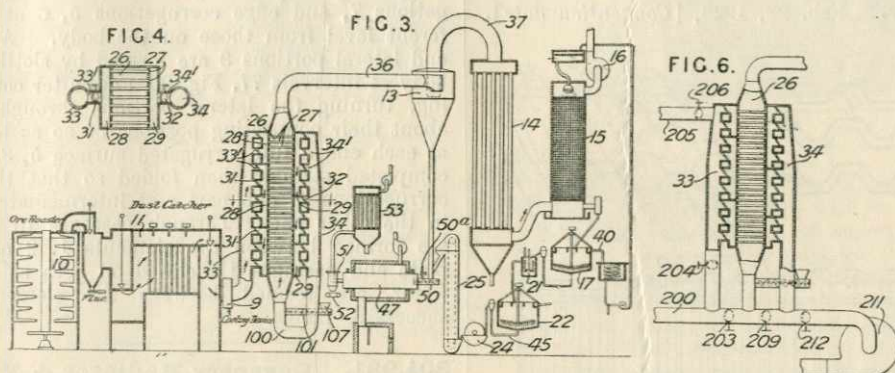

Straight tubes between headers. — In a catalytic apparatus, sulphur dioxide from a roaster 10, a dust-catcher 11, and cooler 9 passes first through a flue 33, through nozzles 33' each of which has a damper 31, into a chamber 28, then through tubes 27 which cross the reaction chamber 26 into a chamber 29, then through nozzles 34' having dampers 32, into a flue 34 connected with the tube 100 and so into the reaction chamber 26. By manipulating the dampers 31, 32 the cool gas may be made to pass through any of the tubes 27 to absorb the reaction heat at any point, and by suitably arranging the dampers the gas may be passed from side to side several times as

the chambers 28, 29 are divided by partitions in staggered relation as shown on Fig. 3. In an alternative form where cooling is required, additional control of the cooling may be effected by arranging the gas supply pipe 200, Fig. 6, with branches to the control tubes 33, 34 and a branch 205 direct to the reaction chamber 26. A pipe 205 for admitting air, and an exhaust fan 211 enable any desired proportion of gas from the pipe 200 or of air from the pipe 205 to be employed for cooling, by manipulating, dampers 206, 204, 203, 200, 212. Specifications 23045/10, 221,229, and 304,251, [all in Class 1 (i), Chemical processes &c.], are referred to.

304,272. Beck, E. F. A. D. Jan. 18, 1928, [Convention date].

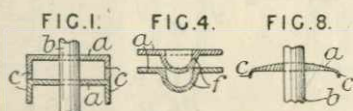

Gills for tubes.—Tubes *b* for hot medium are fitted with plates *a* for example of iron having two down-turned edges *c* or cupped portions *f* so that longitudinal compression can be applied to

the series of gill-plates without deformation. This compression is obtained by internal hydrostatic pressure in the tubes so as to expand the tubes between the plates and thus shorten the total length. In one form, Fig. 8, the plates are of tapering thickness.

The Specification as open to inspection under Sect. 91 (3) (a) comprises also a means of obtaining longitudinal compression by clamping the plates as by tie rods prior to securing them to the tubes by soldering &c. This subject-matter does not appear in the Specification as accepted.

304,728. Anciens Etablissements M. P. Velut. Jan. 25, 1928, [Convention date].

Tube-filled tubes.—In a heat-exchanger having an inner tube 1 for the passage of one fluid and an outer tube 2, the tubes being spaced apart by further tubes 3 through and around which the other fluids flows, in the annulus 4, the tubes 3 are arranged out of contact with one another.

The Specification as open to inspection under Sect. 91 (3) (a) comprises also a form of heat exchanger having the tubes 3 in contact, Figs. 3

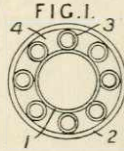

(Cancelled), and 4, (Cancelled), the fluid passing through the inner tube 1, the other being directed by a cross partition in the outer casing passing

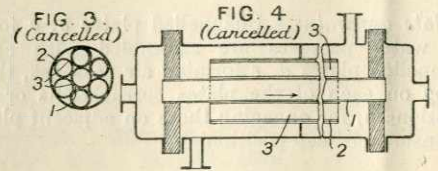

through and around the tubes 2 and 3. This subject-matter does not appear in the Specification as accepted.

304,961. Soc. Anon. des Usines J. Gallay. Feb. 28, 1928, [Convention date].

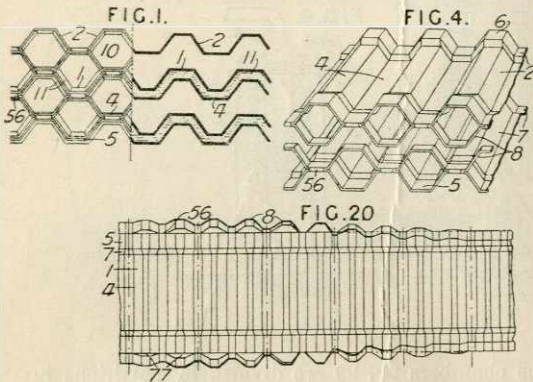
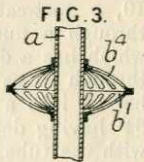

Plate apparatus.—Corrugated plates for radiators, such as for internal-combustion engines, are formed by shaping the lateral edges of a metal strip, and roll-corrugating the strip during a single passage through the machine. Each plate may be formed from a strip of brass &c. which is folded about its middle after shaping so as to form two superimposed elements 1, 2; or each plate may consist of two separate strips superposed and fastened together at their ends. The strip may be formed with trapezoidal corrugations

comprising body corrugations 4, inclined corrugations 7, and edge corrugations 5, 6 at a different level from those on the body. At each end lateral portions 8 are formed by slotting the body at intervals 77, Fig. 20, and, after corrugating, turning the lateral portions through 180° about their connecting portions 56 so as to form at each end a full corrugated surface 5, 8. The completed strip is then folded so that the full corrugations in one part rest intermediate those in the other part. Through passages 10 for air are formed between the elements 1, 2 of each plate and passages 11, closed on both sides, for water, are formed between the elements of successive plates.

304,981. Coventry Radiator & Presswork Co., Ltd., and Jackson, L. H. June 2, 1928. No Patent granted (Sealing fee not paid).

Gills for tubes.—Motor-car &c. radiators are constructed with tubes each having secured thereon a series of gills of hollow skeleton or open formation. In the example two dished perforated plates b^1 , b^4 in reversed order are mounted on a tube a to form each gill, the gills being arranged in close order.



305,172. Samesreuther, R., and Kranzlein, G. Feb. 1, 1928, [Convention date].

Straight tubes between headers; plate apparatus; headers; tube-plates bowed tubes between headers.—Heat-exchanging units are constructed by flanging outwards the ends of tubes a , cutting the edges square and welding the flanged edges of adjacent tubes together as at x . U-shaped collectors c are then welded to the side edges of the flanged parts as at y . If the collectors are deep, transverse strengthening partitions d , Fig. 9, may have been previously welded into place which partitions may be perforated as at d^1 , Fig. 11, to act as fluid distributors. Other partitions d^2

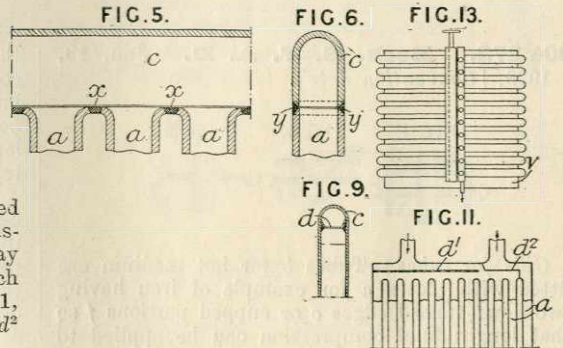

may serve to separate certain tubes. The tubes may be curved as in Fig. 13 where they encircle and are welded to a container *v*. Screw-down valves may be provided in the collectors to control the passage of fluid through any one of the tubes.

turned about its axis to bring the bricks into the vertical position in which they contact with the tubes. The bars *e* may be left in position to serve as ties or they may be removed and fluid binding material poured in to fill the passages *c*, *d*; fluid cement may also be used in conjunction with the bars *e*. Specification 15497/00, [Class 51, Furnaces and kilns], is referred to.

306,243. Fothergill, H. Jan. 3, 1928.

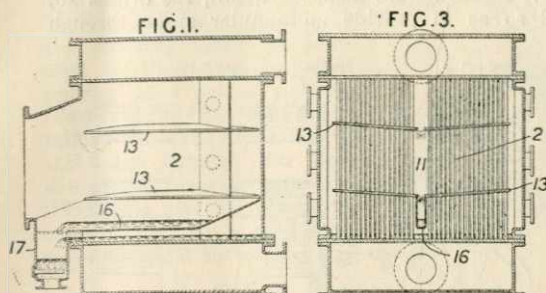

Drip-interception devices.—In condensers with vertical tubes 2, substantially horizontal drip plates 13 are fitted which collect condensate and transfer it to a steam space 11 in the middle of the tube block or to spaces on either side. The condensate collects in a gutter 16 and passes thence to the hot well 17. Specification 249,181, [Class 32, Distilling &c.], is referred to.

307,068. Schmidt'sche Heissdampf-Ges. March 3, 1928, [Convention date].

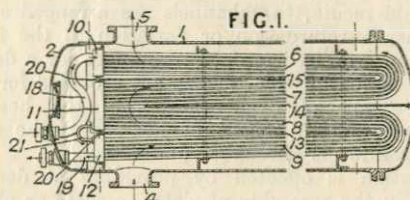

Loop-tube apparatus.—Sets of loop-tubes 6, 7, and 8, 9 or their equivalent with an outer reversing header, join a series of superposed headers 10, 11, 12, one of which only, the inlet or outlet, is held rigidly as by a drain tube 19 secured to the cover 2. The other headers can move under expansion, rollers 20 being provided between the headers. The upper header 10 is connected to a heating steam inlet pipe 18 which is curved to allow for movement. In the example, steam to be superheated enters the casing 1 at 4 and, passing around baffles 13, 14, 15, emerges at 5. A direct connection 21 may be fitted to allow condensate from the upper tubes to pass direct to the outflow.

306,869. Thompson Water Tube Boilers, Ltd., J., and Napier, A. L. Nov. 26, 1927.

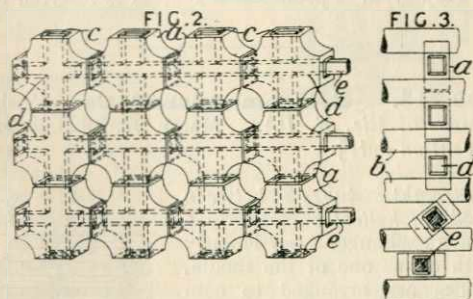

Tube supports.—A baffle wall for heat-exchangers and other tubular apparatus, which can be erected after the tubes are in position, is built up of bricks *a* cut away at the corners to abut against the tubes and having intercommunicating internal passages *c*, *d*. In assembling the wall, a row of bricks is threaded on an iron bar *e* and inserted as a unit between the tubes *b* as shown at the bottom of Fig. 3; the bar is then

307,191. Serck Radiators, Ltd., and Hepworth, F. Feb. 11, 1928.



Gills for tubes; plate apparatus.—In radiators having corrugated metal plates *a* in pairs forming water spaces with air spaces between the pairs, an additional strip *b* is placed between the main strips, corrugated to a pitch smaller than that of the main strips with curved or angular corrugations.

307,425. Seligman, R. March 7, 1928,
[Convention date].

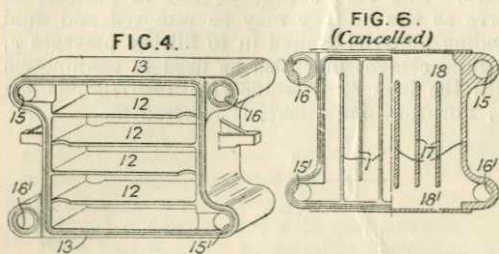

Plate apparatus. — In a heat-exchanger composed of plates furnishing zig-zag channels for the fluid media, the channels are arranged so as to cause a retardation or variation in the flow, to attain a desired temperature effect for a determined period of time, means are provided for the rapid escape of condensate from the heating medium, and by means of bye-passes the final temperature is brought under control. The retardation is effected by providing at desired points in the assembly of plates, a plate or plates affording a larger cross-sectional area of flow such as 13. Fig. 4 which has internal baffles 12 to effect a zig-zag path and would be closed on both sides by plane faced plates with channels for the heating or cooling medium. Ports 15, 15', 16, 16', are provided for entry and escape of medium or for carrying medium through to other parts of the apparatus.

The Specification as open to inspection under Sect. 91 (3) (a) comprises also shallow plates as in Fig. 6 (Cancelled) which shows ribs 17 for causing a zig-zag path for the treated medium. The adjacent channels for heating medium are provided with parallel ribs 17 for causing steam to flow directly across from the space 18 to the space 18' whereby condensate can be evacuated readily. This subject-matter does not appear in the Specification as accepted.

307,843. I. G. Farbenindustrie Akt.-Ges. March 14, 1928, [Convention date].

Materials for making. — Surface apparatus for chemical reactions involving heating ammonia gas to temperatures exceeding 400° C. is constructed of copper, silver, aluminium, magnesium, silicon, and their alloys.

307,854. Nielsen, N. J. Dec. 12, 1927.

Straight tubes between headers or connecting boxes. — In a tubular heating system for use in sterilizing milk &c. units 9, 11, 16, 17 are each formed of parallel tubes in sets of three, the front ends of which are fixed in the common

front wall 40 of the drums 10, 12 and communicate with recesses 48 therein. The two upper recesses 48 communicate through flanged pipes 44 with the inlet and outlet respectively of a heating system and the two lower recesses 48 through flanged pipes 45 with a pump and a cooling system respectively. The recesses 48 are closed by lids 54, and passages 46 connect the upper and lower recesses on the pre-heating and pre-cooling sides respectively. The rear ends of the tube systems communicate through recesses 41, in plates 47, closed by plates 49. Tubes 50 are disposed within the drums 10, 12 so as to provide an annular space through

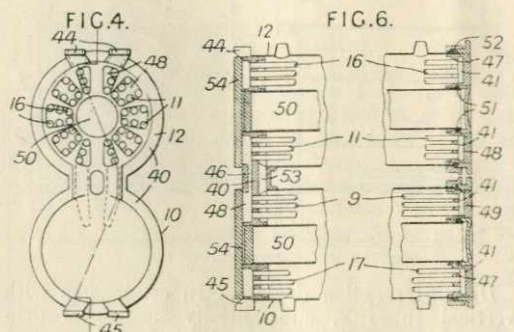

which the water circulates transversely of the tube systems, the upper annular space being connected through an opening 53 with the lower. Separate rear end plates 49 are provided for each of the pre-heating and the pre-cooling systems 9, 11, 16, 17 and sealing members 52, 51 are employed for these systems and for the tubes 50 so that relative axial expansion and contraction due to temperature differences is provided for. A further pair of drums each having a pre-heating and a pre-cooling tube system may be inserted between drums 10, 12. A rise or fall of temperature 15–35° C. may be obtained in each of the pre-heating and pre-cooling systems. Jackets and tubes of any polygonal cross-section may also be employed. Specification 185,221 is referred to.

308,715. Grisco-Russell Co., (Assignees of Ris, K. B.). March 27, 1928, [Convention date].

Straight tubes between headers; helical baffles. — In a heat-exchanger particularly with oil as one of the media, baffles are arranged to constrain the medium alternately in a multi-helical circumferential direction and in an axial direction. In the example plane baffles 15 through which the tubes 5 pass, having a central opening alternate with baffles 14 having sectors bent up like propeller vanes. Specification 176,753 and 248,712 are referred to.

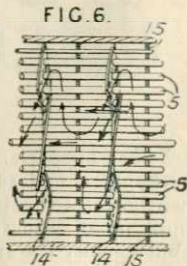



308,966. Superheater Co., Ltd., (Assignees of *Compagnie des Surchauffeurs*).
2, 1928, [Convention date].

Straight tubes closed at one end.—A series of tubes 1 inclined to the vertical connected at their open ends to a header 3, the other ends 2 being closed, is mounted in a casing 4. Passages 5, 6 for the fluid being treated are ports 7, 8 for the steam or the heating medium. In Fig. 1 the entering steam is delivered to the tubes by short nozzles 13 from a separate compartment 11, condensate falling from the underside of the tubes through the same end of the tubes to compartment 12. In Fig. 3 the header and the compartments are formed by tubes 3, 3^a. In a modification the header 3 is undivided and no nozzles are used.

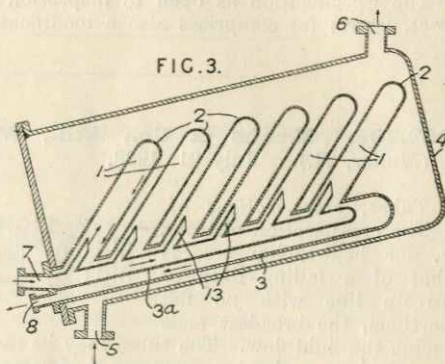
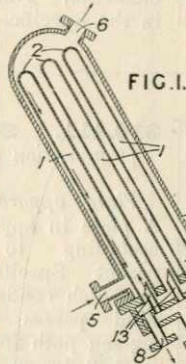

The Specification as open to inspection under Sect. 91 (3) (a) comprises also the use of vertical instead of inclined tubes. This subject-matter does not appear in the Specification as accepted.

309,106. Quiggin, D. A. Jan. 2, 1928.

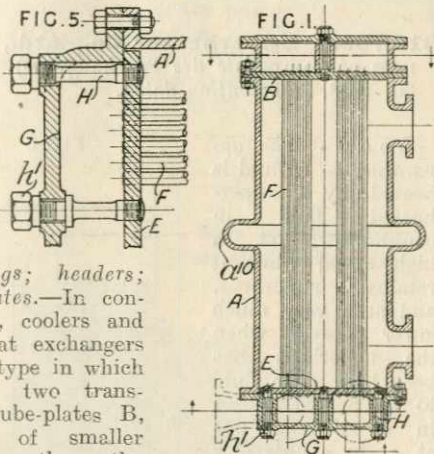

Casings; headers; tube-plates.—In condensers, coolers and like heat exchangers of the type in which one of two transverse tube-plates B, E is of smaller diameter than the interior of the casing A to enable the tube bank F, with its tube-plates, to be withdrawn from one end, the smaller tube-plate E is jointed to a facing on the end header G by means of bolts &c. H passing in fluid-tight manner through the header, in one example through cored holes, and secured by cap nuts h'. The tubes may be straight or coiled. The casing A is provided with means such as the U-bend a¹⁰ to accommodate expansion.

309,445. Kranzlein, G., and Samesreuther & Co. Ges. April 10, 1928, [Convention date].

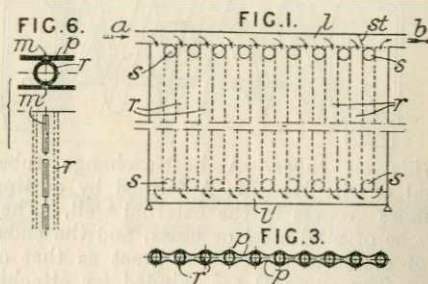

Straight tubes between headers.—A heat-exchanger adapted for use as a radiator for heating buildings or as a water heater comprises tubes r connecting top and bottom headers l, l', plates p which may be flat or corrugated as shown in Fig. 3, being welded or soldered to the sides of the pipes. A partition st may be placed in the header l to cause the outflow b to be at the same end of the inflow a. Holes s at top or bottom of the side sheets p, or at both, allow of entry of air, for example, to the spaces between the pipes. When used as a radiator the device may be built in a wall, for example, separating two rooms. As a water heater, electric elements may be introduced into the spaces between the pipes, through the openings s or from one end if the header is displaced sideways, the water to be heated flowing through the pipes r. Fig. 6 shows a method of securing, the plates being slotted as at m opposite the pipes and solder applied to the slots. The pipes may be split and splayed at

their ends and then welded to openings in the header pipes. The openings may be progressively larger the further from the entry point *a*.

The Specification as open to inspection under Sect. 91 (3) (a) comprises also a modification in

which the headers at one end are displaced laterally to leave the spaces between the pipes open for the direct insertion of electric heating elements. This subject-matter does not appear in the Specification as accepted.

309,798. Kochs & Co., Ltd., W. E.,
(Muller, H.). July 21, 1928.

Tubes, cross-sections of.
—The cross-section of tubes *a*, for heat-exchangers, is that of a falling drop or stream line with no flat portions, the broadest ends facing the fluid flow. The tubes may be mounted in end-plates *e*, having apertures *f* of corresponding shape, either in parallel formation, as shown, or in staggered relation. Specifications 16823/03 and 19784/05 are referred to.

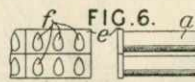

310,411. Seligman, R. April 25, 1928,
[Convention date]. Addition to 327,377.

Plate apparatus.—A plate in apparatus according to the parent Specification in which condensable fluid passes in a zig-zag path from an inlet 2 to an outlet 3 is provided with baffles 4, 5, those 5 united to the bottom having apertures 6 of increasing size, the nearer to the outlet for the ready clearing of condensate.

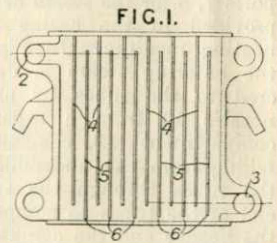

309,845. Carrier Engineering Co., Ltd., and Owen, W. H. Jan. 16, 1928.

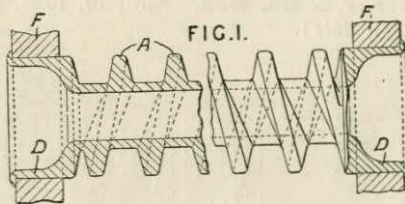

Gills on tubes.—A heat-exchange tube has spiral or circular gills *A* formed by cutting one or more grooves in the external wall. The tube may be of mild steel or brass, and the ends may be of diameter at least as great as that of the gills. The edges *D* are thinned for attaching to the tube plate *F* by rolling or expanding.

310,799. Superheater Co., Ltd., (Assignees of *Compagnie des Surchauffeurs*). April 30, 1928, [Convention date].

Loop-tube apparatus.—A fluid is heated by a superheated fluid in counterflow, at a high speed while it retains superheat, and at a very much lower speed when the superheat has been lost. The fluid to be heated passes in at *d* and out at *g*, in counterflow to the heating fluid which enters at *e* and passes at high speed through pipes *b* before flowing through tubes *i* to headers *h* connected to condensing tubes *k*, closed at the top, and to a condensate outflow *m*.

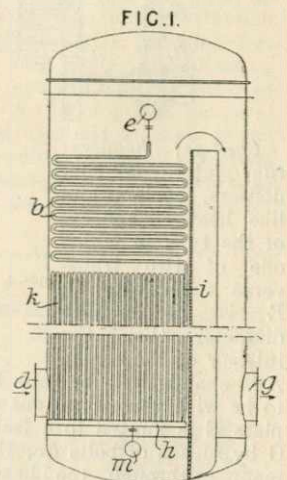

310,327. Akt.-Ges. Brown, Boveri, et Cie. April 23, 1928, [Convention date].

Casings; tube-supports; bowed-tubes between headers.—In a heat-exchanger for high pressures employing tubes secured at their ends to tube-plates welded &c. to the casing 14, the casing is made in at least two parts 14, 15, the part 15 being welded or bolted in position only after the tube stack, the tube-supporting plate 9 and guides 13 for the edges of the plate have been secured in place. Specification 165,053 is referred to.

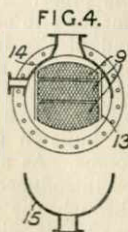



310,819. Skoda Works, Plzen. April 30, 1928, [Convention date].

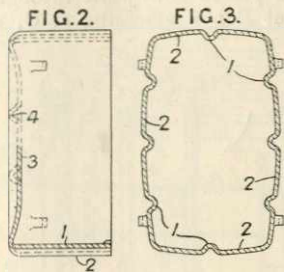

Headers for heat-exchangers are constructed with inwardly arched ends 3 and outwardly arched side walls 2 stiffened by corrugating as at 1. The ends 3 may also be stiffened similarly

as at 4. The thickness of the metal is the same throughout or does not exceed two and a half times the thickness at any one part.

310,880. Trent Process Corporation, (Assignees of Trent, W. E.). May 2, 1928, [Convention date].

Materials for making.—The rate of heat transfer in a mercury-vapour boiler is increased by surfacing the parts of the inside wall exposed to mercury with a substance wetted by mercury. A non-ferrous metal such as silver or an alloy may be used. The boiler-tubes may be constructed entirely of the metal or alloy.

311,092. Marks, E. C. R., (Royal Baking Powder Co.). May 4, 1928.

Tubes, cross sections of.—A tube 24 of non-resilient metal such as lead is supported externally at its ends, and intermediately by a rigid internal member 25 which is substantially as long as the tube 24 and of such construction as to allow of the passage of heat-exchanging medium. The member may be a perforated tube 25, as in Figs. 2, 4, a star-shaped tube 26, Fig. 5, a star-shaped rod 27, Fig. 6, or a twisted strip.

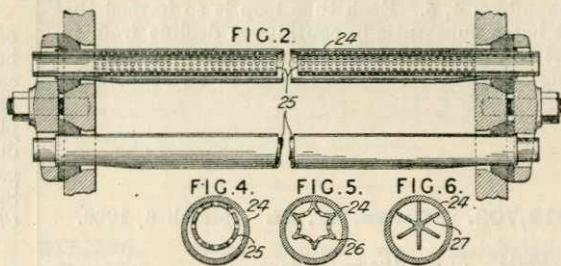

311,245. Torre, E. May 7, 1928, [Convention date]. Void [Published under Sect. 91 of the Acts].

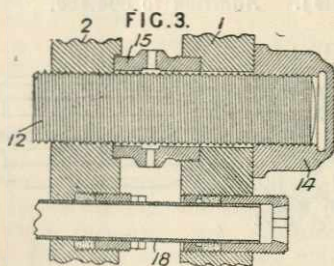

Tube-plates.—At one or both ends of the tubes 18 of a surface-condenser, double tube-plates 1, 2 are provided, the space between being filled with pure water under a pressure slightly greater than that existing in the normal cooling water system. Stays 12 are screwed into the inner tube-plate 2, a perforated distance-sleeve 15 spacing out the second tube-plate 1, a cap nut 14 securing the whole.

311,574. British Thomson-Houston Co., Ltd., and Dumas, R. June 7, 1928.

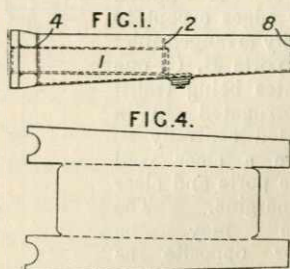

Headers for the radiators cooling oil &c. surrounding transformers &c. are made with transverse perforated stiffening partitions 2 securing the inner ends of the tubes 1, connecting to the main tank, these tubes extending through the end plate 4 and all joints being welded. The header may be made in one piece, Fig. 4, for bending into shape with side and end walls ready for welding to the tube-plate. Other methods of making are described in which one or both end plates 4, 8 are separately welded to a sheet form-



ing, when bent, the other sides. Specification 287,624 is referred to.

312,470. Superheater Co., Ltd., (*Compagnie des Surchauffeurs Soc. Anon.*) May 4, 1928.

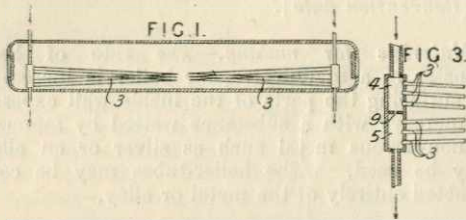

Loop-tube apparatus.—A heat-exchanger applicable for generating steam by heating-medium in a closed circuit, comprises loop-tubes 3 connected at their ends to superposed header chambers 4, 5. Each tube loop is so formed that it has a substantially continuous decline from inlet to outlet and a duct 9 of small area connecting the header chambers to drain off condensate.

312,702. Owen, W. H. March 6, 1928.

Plate apparatus.—Heat-exchanging cells for use in apparatus as described in Specification 228,218, [Class 64 (i), Heating liquids &c.], are formed by two juxtaposed thin metal sheets A united along their edges except to leave laterally arranged inlet and outlet ports B, C, one or both plates being transversely corrugated in a panel situated centrally so as to leave a clear wall adjacent the ports and clear lateral margins. The corrugations may be parallel, or opposite as shown in Fig. 4.

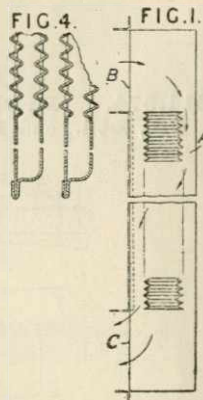

313,114. Owen, W. H. March 6, 1928.
Divided on 312,702.

Plate apparatus.—In cellular heat exchangers in which the media flow in opposite directions, the walls of each cell are corrugated transversely

to one another, the cells having laterally opening inlet and outlet ports. In the example air to be heated passes downward through the cells A entering at B and emerging at C, the bundle

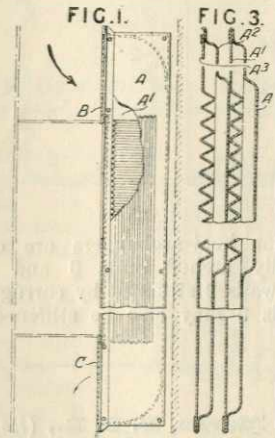

of cells being mounted in a flue up which hot gases are passing. Plates A - A³ are corrugated with the corrugation on adjacent plates at right angles and formed in panels with plain surrounds, such panels being in some cases dished as shown to cause the whole of the corrugation to lie on one side of the plain surround. Specification 228,218 and 273,809, [both in Class 64 (i), Heating liquids &c.], are referred to.

313,140. Kuhlerfabrik Langerer & Reich Akt.-Ges. June 8, 1928, [Convention date]. Addition to 304,183.

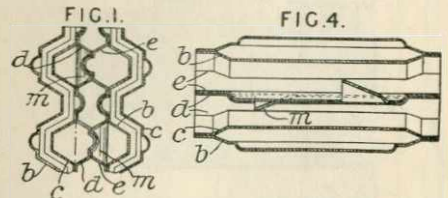
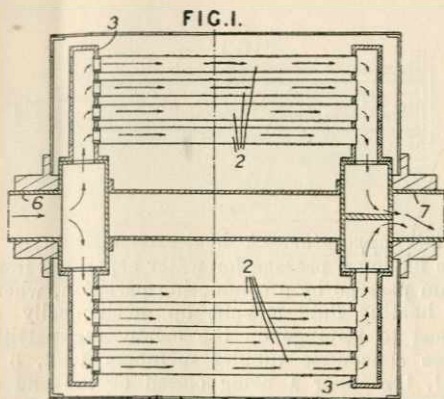

Plate apparatus; gills for tubes.—In a heat-exchanger according to the parent Specification with water holding plates b, c, the intermediate plates are provided with pressed-out fins m to deflect the air current on to the water holding plates. Pairs of intermediate plates d, e may be formed by doubling a single sheet.



313,780. **McNeil, G.** July 11, 1928.



Rotary straight tube apparatus.—A tubular structure connected to inlet and outlet axis pipes 6, 7 comprises radial headers 3 connected by tubes 2, each header with its tubes comprising a separately removable unit.

313,998. **White, W. A.** March 21, 1928.

Plate apparatus.—A heat exchanger is built up of a number of self-contained open-ended cells 2 similarly disposed with their open ends juxtaposed and directly connected together, each cell having corrugated metal sides and a duct therebetween running from end to end in a direction transverse to the corrugations, while the corrugated sides of adjacent cells are spaced apart forming vertical passages 3. Each cell is closed top and bottom by sinusoidal plates 2^a, 2^b splayed or enlarged at the ends so as to space the cells apart. The plates 2^a, 2^b may be welded in place or held in position by light bolts connecting the top and bottom plates, in which case they are provided with shoulders to limit the distance they enter into the cells. The invention is shown applied to the preheating of air for boilers, the heat exchanger being in halves and the air passing from the centre outwards to ducts leading to the furnace. The air may make a number of passes through the heater either at the same level or at different levels.

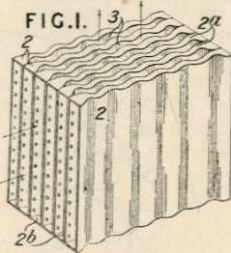

314,433. **Soc. Anon. des Anciens Etablissements Liotard Frères.** June 27, 1928, [Convention date]. Void [Published under Sect. 91 of the Acts].

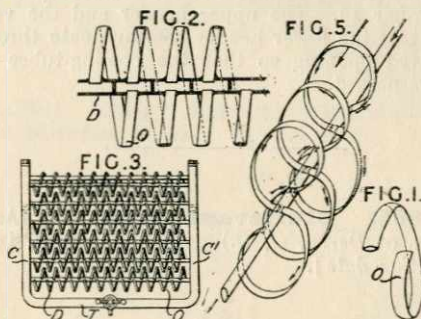

Coil-tube apparatus.—A cooling-water radiator for motor vehicle and aeroplane engines comprises collectors C, C', Fig. 3, connected by a valved-pipe T and air-cooled elements each comprising a central tube D, Fig. 2, having compartments connected in series by spiral metal tubes O of flat or elliptical cross-section. Fig. 5 shows a modified form of element particularly suitable for aeroplane engines. In another arrangement, the elements each consist of a central partitioned tube connected at its end by a coiled pipe formed by joining the tubes O in series.

315,266. **Soc. Anon. des Anciens Etablissements Liotard Frères.** July 10, 1928, [Convention date]. Void [Published under Sect. 91 of the Acts].

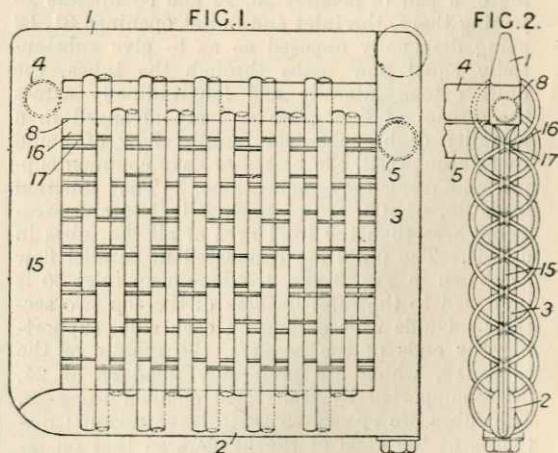

Serpentine-tube apparatus.—An aeroplane &c. radiator comprises an upper header 1 having a distribution duct 8 and to which water to be cooled is supplied through a pipe 4 and a lower header 2 having a vertical rear leg 3 with a cold water outlet 5, the upper header and its duct being connected to the lower header by pairs of

cooling-tubes having a flattened cross-section in the direction of the air stream and defining circular spaces through which the air flows. The cooling-tubes are held in place by bars 16, 17, and the headers are connected at the front by a stiffening-bar 15. The upper header and the vertical leg of the lower header communicate through a valved opening so that the cooling-tubes can be bye-passed.

315,865. Sturtevant Co., B. F., (Assignees of *Derry, G. C.*). July 21, 1928, [*Convention date*].

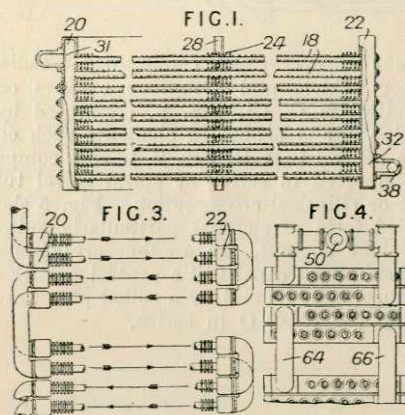

Straight tubes between headers.—In a heat exchanger described for use as a feed-water heater, and comprising a succession of units each consisting of a pair of headers 20, 22 and conductors 18 joining them, the inlet and outlet openings 31, 32 being diagonally opposed so as to give substantially equal flow paths through the tubes, the units extend laterally and longitudinally across the stream of flue gases and are arranged in a plurality of branches for parallel flow of liquid therethrough; all the branches have common supply and discharge connections. The junction leads 38, 64, 66, are of materially less cross-sectional area than the total area of all the tubes in a unit. The units are connected in parallel flow as shown in Fig. 3 and 4, wherein an inlet 50 is branched to the inlet headers of the top two sections. Guide rails extend on each side, supporting the ends of the headers, the middle of the tubes 18, which are preferably filled as at 24, being supported by transverse channel irons 28. The tubes are spaced so as to leave unequal distances at the ends of the headers so that on reversing adjacent units the tubes are placed in staggered relation.

316,699. Wyndham, J. N., and Wyndham, S. L. Nov. 23, 1928.

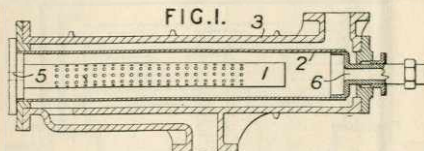

Plate apparatus.—A heat-exchanger is of the type having a passage for water separated from a steam passage by a conducting partition, wherein the heating fluid is split up mechanically and caused to impinge on the conducting partition. Three concentric tubular members 1, 2, 3 are used, the inner 1 being closed at the end and perforated to cause steam admitted at 5 to impinge in the form of jets against the member 2, which is arranged in the outer casing with an expansion joint 6 which can readily be broken to facilitate removal of the tube 2.

316,718. Howden & Co., Ltd., J., and Hume, J. H. May 23, 1928.

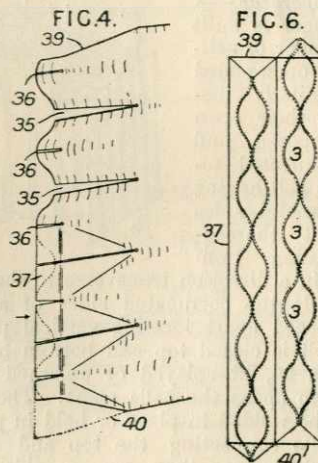
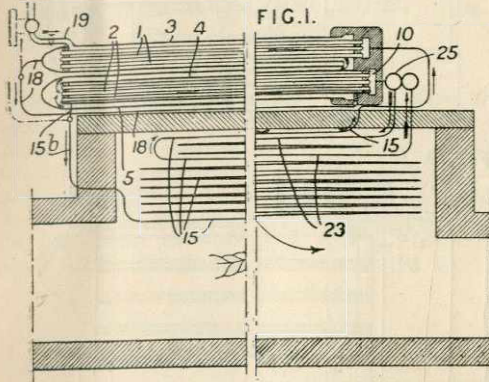

Plate apparatus.—A heat-exchanger is made up from corrugated sheets, the edges of which are suitably slit as at 35, 36 and flattened out to make a plane selvage 37, pairs of sheets being assembled with their corrugations touching, and welded to form parallel ducts 3 for one fluid, adjacent pairs forming sinuous ducts for the other fluid between them. Filling pieces 39, 40 are welded to the top and bottom ends. Specification 295,106 is referred to in the Provisional Specification.



316,918. Superheater Co., Ltd., (*Compagnie des Surchauffeurs, Soc. Anon.*). May 4, 1928.



Straight tubes between headers or connecting-bores.—Heat exchange apparatus of the kind in which one fluid is heated indirectly by the circulation of another fluid in a closed circuit comprises one or more units each consisting of at least two connected multitubular drums 3, 5 through which the heated and the heating fluids flow in series. In a steam boiler heated by the circulation of steam generated in tubes 15 heated by furnace gases, the heating steam passes through tubes 1 in one of the drums 3 of a heat-exchange unit and is then led through a pipe 18 to the opposite end of the unit into a casing 4 around the tubes 2 in the other drum 5. Condensed steam is returned to the generating tubes through a pipe 15^b. Water supplied to a unit by a pipe 19 flows first through the drum 3 and then through the annular space between the drum 5 and the casing 4, and finally through the tubes 2 into the outlet header 10.

tube, the jacket space e^2 for the refrigerant tapering towards the top to retard the outflow of vapour. The elements may be connected to supply and discharge headers e^6 , e^5 .

319,099. Dairy Accessories Co., Ltd., and **Martin, E. A.** July 19, 1928.

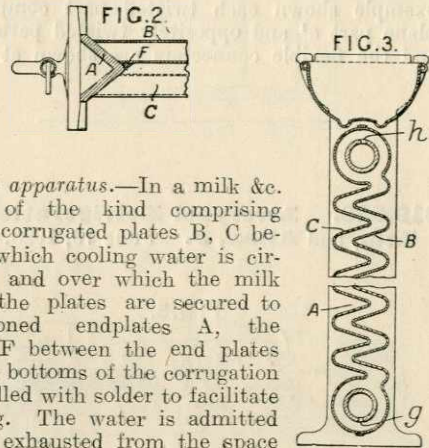
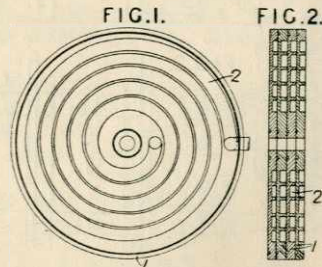
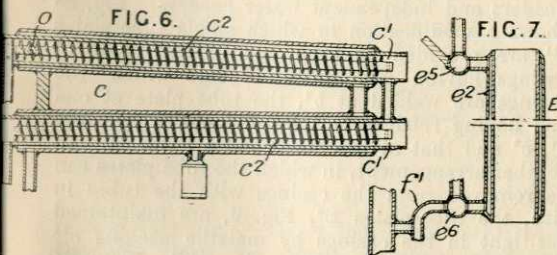

Plate apparatus.—In a milk &c. cooler of the kind comprising spaced corrugated plates B, C between which cooling water is circulated and over which the milk flows, the plates are secured to V-sectioned endplates A, the spaces F between the end plates and the bottoms of the corrugation being filled with solder to facilitate cleaning. The water is admitted to and exhausted from the space between the plates through perforated ducts g, h respectively.

319,621. Boer, F. de. Sept. 24, 1928, [Convention date]. Void [Published under Sect. 91 of the Acts].



317,598. Shaw, J. C. July 6, 1928.



Concentric-tube apparatus; tubes with internal baffles.—A spiral baffle c^2 , Fig. 6, is provided in the inner water conduit c^1 of a concentric tube condenser C of an absorption refrigerating apparatus. An evaporator element E, Fig. 7, may consist of a vertical open-ended jacketed

Plate apparatus.—Plates 1 are provided on one or both sides with spiral grooves 2 forming passages for fluid when the plates are assembled, either directly together or with plane plates between them. The plates are preferably mounted on a central shaft along which they may be readily moved on separation and revolved for cleaning.

319,626. Kent, S. N., and Billetop, T. C. June 18, 1928.

Tubes with internal baffles.—Retarders for inserting in tubes of heat exchangers or exhaust pipes comprise lengths of twisted strip metal connected by flexible parts of smaller cross-section for example wire. In the example shown each twisted part comprises a plane part a^1 and oppositely twisted parts a^2 , a^3 and the flexible connectors are shown at C.

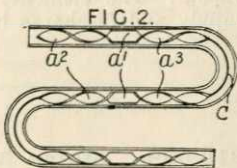

319,628. Liverpool Refrigeration Co. Ltd., and Allan, J. June 19, 1928.

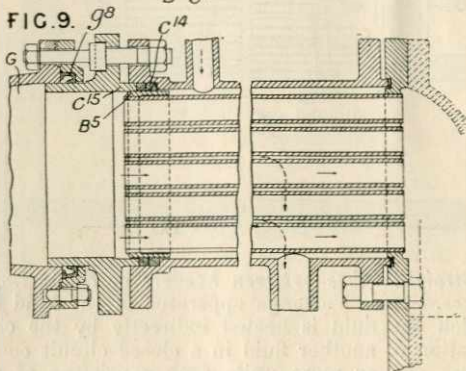
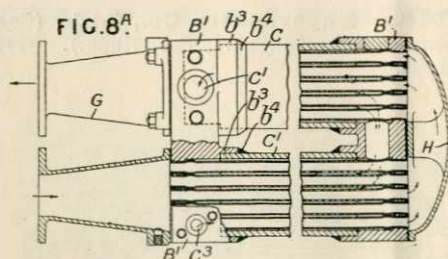
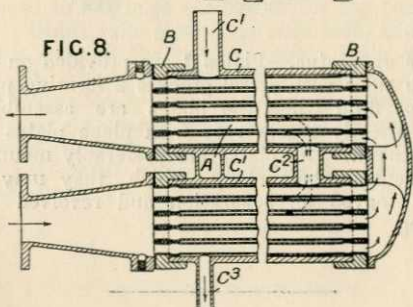
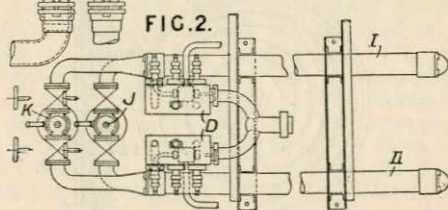
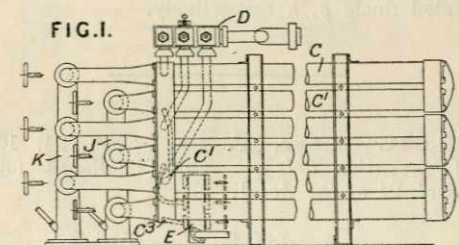
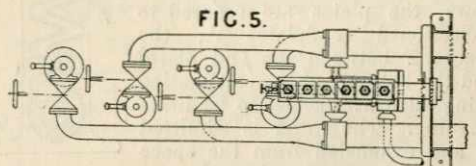

Straight tubes between headers or connecting-boxes.—A condenser for refrigerating apparatus particularly for use on ships comprises tiers I, II, Fig. 2, of unit condensers each comprising a pair of casings C, C', Fig. 8, connected by a tube c^2 and having refrigerant inlet and outlet pipes c^1 , c^3 and cooling water tubes A expanded or welded in tube-plates B, each unit being independently connected to cooling water inlet and outlet headers J, K and refrigerant inlet and outlet headers D, E so that it may be disconnected from the condenser for repair &c. without interfering with the operation of the remaining unit. Fig. 5 shows a more compact arrangement in which the casings in each tier are provided with common refrigerant headers and independent water headers. Fig. 8^a shows a modification in which single tube-plates B¹ are provided at each end of each pair of casings having extensions b^3 into which the casings are welded at b^4 , the tube plate at one end having refrigerant inlet and outlet openings c^1 , c^3 and that at the other end a cover H. In another arrangement, in which the tube-plates can be removed from the casings with the tubes in situ, the tube-plates B⁵, Fig. 9, are maintained gas-tight in the casings by metallic packing c^{14} held in position by glands c^{15} , while Victualic rings g^8 maintain liquid-tight joints between the glands and the water headers. In a further modification, the casings are secured to the tube-plates by rings c^9 and nuts b^{13} .

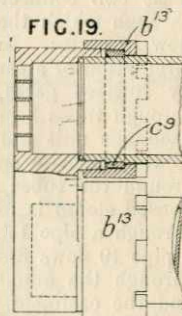

320,171. Serck Radiators, Ltd., Purchase, S. N., and Upton, H. E. Aug. 2, 1928.

Headers of heat-exchangers are provided with one or more baffles *c, d, f*, adapted to produce a deflection of the stream of water flowing to tubes or other surfaces, such as will facilitate the separation of occluded air and allow it to pass to the upper part of the header whence it can be withdrawn as through a cock *g*. Specifications 11219/07 and 258,912 are referred to.

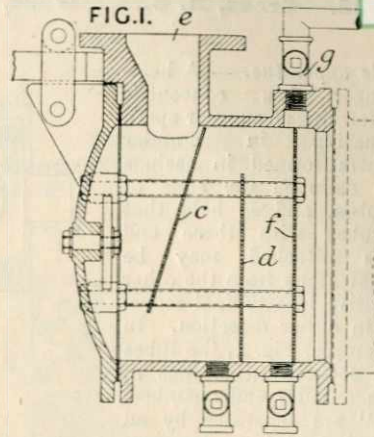

320,279. Heenan & Froude, Ltd., and Walker, G. H. Dec. 11, 1928.

Plate apparatus. — In a heat exchanger in which a convoluted sheet *A* forms a heat-transmitting partition between compartments *A*¹, *A*² formed by the convolutions and the outside walls of a containing chamber, ports as at *c, e* serve to connect the compartments on each side of the sheet *A* in series. In a modification, Fig. 7, the convoluted sheet *A* fills an annulus, the ports *g*¹, *g*² connecting the convolutions in series being formed in the annular rings at top and bottom.

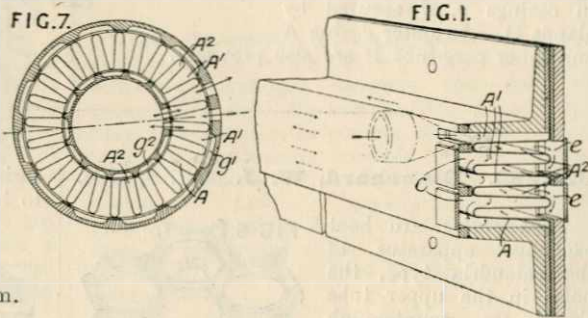

320,283. Babcock & Wilcox, Ltd., (Babcock & Wilcox Co.) Dec. 15, 1928.

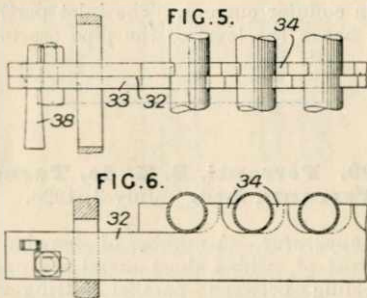

Tube-supports. — In a fuel economizer tubes are held about the middle of their length by supports comprising two strips *32, 33* with notches *34* somewhat deeper than half the diameter of a tube, so that when the strips are moved in opposite directions each tube is clamped between the opposite edges of the notches in the two strips which are then held fast as by wedges *38*.

321,820. Garratt, L., and Coventry Motor Fittings Co., Ltd. Nov. 10, 1928.

Gills for tubes of motor car radiators have the metal between the central aperture *c*, through which the tube passes, and the periphery *b*, re-arranged as by punching out to form a number of holes *a*¹ and free edges *a*² projecting from the plane of the gill without contacting with adjacent gills. Examples are shown of gills with holes or slots of various shapes edged with sharp edges and in Fig. 12 tongues *a*⁴ are pressed out of the metal.

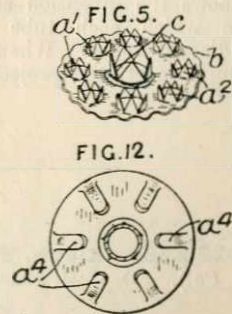

321,833. Cross, R. C., and Ware, H. M. Nov. 21, 1928.

Plate apparatus.—A heat-exchanger has concentric tubes forming an annular space terminating in annular chambers formed in casings which embrace the ends of the tubes, and so held that the tubes with these end casings attached may be withdrawn one from the other by relative longitudinal movement in either direction. In the example, Fig. 1, the tubes A, B, secured in casings *a*, *b* with annular end chambers *a*¹¹, *b*¹¹ are separated by an intermediate tube *c* terminating in packing glands R which when screwed home render the spaces between the tubes fluid-tight. In Fig. 2, the tubes C, D terminate in casings *c*, *d* secured by glands G. An outer casing A and inner core-tube B are also provided.

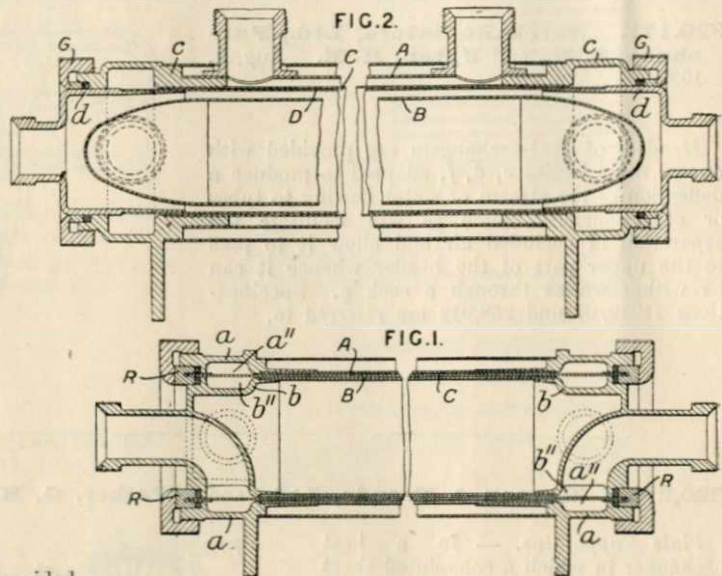

322,280. Blanchard, W. J. Oct. 9, 1928.

Tube plates.—In heat exchange apparatus of the calandria type, the holes in the upper tube sheet are countersunk until the countersinks meet or nearly meet, thereby forming surfaces sloping towards each hole such that sediment cannot lodge thereon. The tube plate may be made thicker than normally to accommodate the countersinks. Fig. 6 shows the invention as applied to a tube plate in which each tube is equidistant from its adjacent tubes. When the countersinks do not quite meet, the projections 21 may be rounded off.

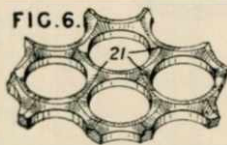

series of tubes 20 is arranged so that the liquid to be treated passes through them generally up-

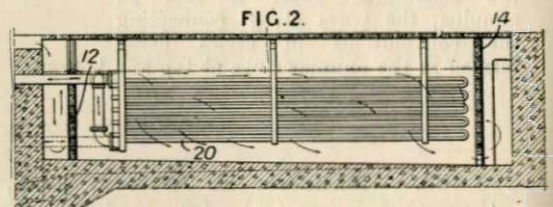

wards in counter current. The inlet partition 12 extends above the level of the pipe assembly 20.

322,366. Dehn, F. B., (Whitlock Coil Pipe Co.). Dec. 24, 1928.

Loop-tube apparatus.—Waste hot liquids are passed through a chamber, or series of chambers, in each of which they enter by an inlet extending the whole width such as over a weir 12 and pass generally downwards to the other end through an outlet again extending the whole width for example under a partition 14, whence they may pass over another weir either to waste or to another chamber. In each chamber a

323,499. Ferranti, S. Z. de, Turner, J., and Ferranti, Ltd. July 3, 1928.

Plate apparatus.—A number of elements *a* each constructed of welded sheet metal are united by edge-welding between parallel butting surfaces either internally as at *e*, Fig. 3, or externally, or by welding-in distance collars *o*, Fig. 10. The unit thus formed is supported by a rigid arm such as a slotted tube *g*, Fig. 3, or a built-up support *n*, Fig. 11. The units may be mounted so as to project radially from the main casing of a transformer cooler, for example, or to be held tangentially by means of a T-piece. Specification 299,998 is referred to.

(For Figures see next page.)



323,499.

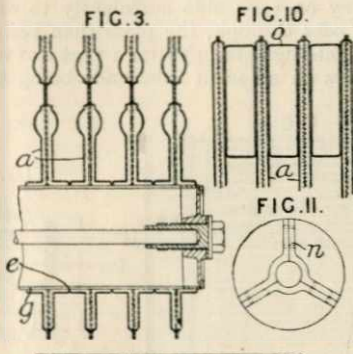

325,249. **Sturtevant Engineering Co., Ltd., and Burrow, W. C.** Sept. 17, 1928.

Gills for tubes. — Gills are closely packed on a tube 5 and are formed of separate plates 1 having shallow radial corrugations or undulations, the curvature of one gill conforming with, and being parallel to that of adjacent gills so that air or other fluid passing between the parallel edges and the curved surfaces of the gills will be given an undulating motion. In an example four or five corrugations only are given to each gill. Preferably the gills have a shoulder round the central hole, and they are secured by expanding the tyre. Specification 3026/05 is referred to.

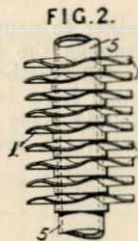

against the webs of the tubes and are welded thereto.

326,278. **Birmingham Aluminium Casting (1903) Co., Ltd., and Pritchard, F.** Dec. 31, 1928.

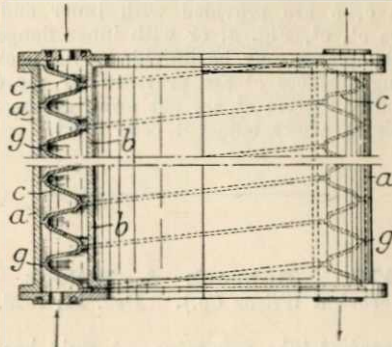
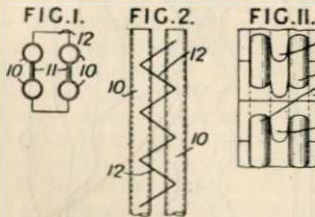

Plate apparatus.—A single partition *c* helically waved to form a helically waved cylinder is removably arranged between two concentric casings *a, b*, with the crests of the waves, which may have a rib *g*, in contact therewith so as to form two continuous enclosed helical passages, which intermesh, for the counterflow of the heat exchanging fluids. Specifications 22135/01, [Class 29, Cooling &c.]; 213,149; 213,877 (as open to inspection under Sect. 91 of the Acts) and 280,577, [both in Class 29, Cooling &c.], are referred to.

325,742. **Mather, C.** April 16, 1929.



Tubes, cross-sections of; gills for tubes.—In tubular radiators, twin or multiple tubes 10, Figs. 1 and 2, connected throughout their length by isolating webs joined at 11 are built up preferably in staggered relationship and are provided with gills 12 folded into zig-zag form to embrace wholly or partly some or all of the tubes. A pressing or staying effect is thereby exerted on the tubes, preventing the web from opening. The ends of double tubes may be expanded to form one connecting end for the headers. In a modification, curved slits are made between the holes forming tongues 15, Fig. 11, which lie along and

326,381. **White, W. A.** April 11, 1929.
Addition to 313,998.

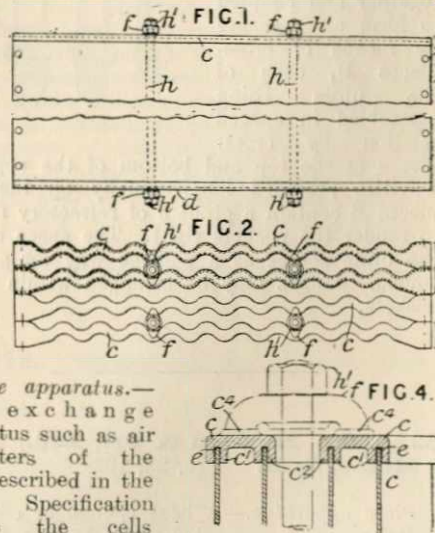

Plate apparatus.—Heat exchange apparatus such as air preheaters of the kind described in the parent Specification have the cells assembled in groups

with the detachable top and bottom plates secured in place by means common to a number of cells in each group. If desired the top or bottom plate only may be detachable. The top and bottom plates *c, d* are secured by bolts *h* and nuts *h¹* carrying dogs *f* which engage with the detachable top and bottom plates of two or more cells. Each dog may be common to two cells, and the group may consist of three or more cells with the dogs in staggered relation. The plates *c, b* are provided with inner and outer flanges *c¹, c²*, Fig. 4, or with inner flanges only and the plates may be provided with packing *e*. Bearing surfaces *c¹* are provided for the dogs *f*. The outer flanges *c²* are cut away at the end of the plates where adjacent cells meet.

326,470. Babcock & Wilcox, Ltd.,
(Babcock & Wilcox Co.). Dec. 11, 1928.

Serpentine-tube apparatus.—A fluid heater for example an economizer comprises a number of **U**-tubes arranged in rows the joints on each row being arranged in line, and the joint comprising

lugs 21, Fig. 5, formed near the tube ends and plates 22 each provided with a hole for the tube, cut away on each side sufficiently to enable the lugs to pass through, the plate then being turned so that the lugs are opposite a part not cut away, the plates on adjacent tube ends being bolted to-

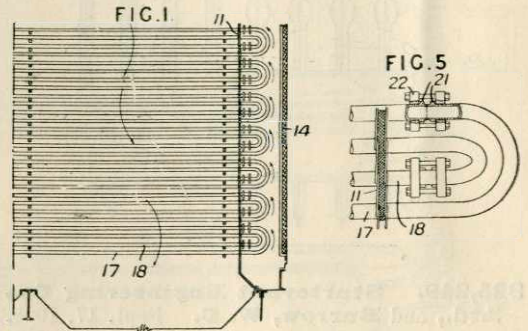

gether to cause the tube ends to about. In the example the **U**-tubes are in pairs 17, 18 connected together to form a serpentine heater, the joints lying between the outer casing 14 and a wall 11 made up of plates slotted so as to fit between the rows of tubes.

326,981. Etablissements G. Desson et Cie, and Desson, G. March 5, 1929.

Materials.—Heat exchangers comprise the combination of a number of pairs of plates of fibrocement *F* connected together and adapted to form air passages by means of cross-pieces *B*, each of the units being assembled in spaced relation by cross-pieces at the top and bottom of the apparatus. Cavities provided longitudinally on the cross-pieces *B* contain a grout *c* of refractory material to render the pockets tight. The space between the units serves as a passage way for gases or smoke. Baffles may be arranged within the air pockets.

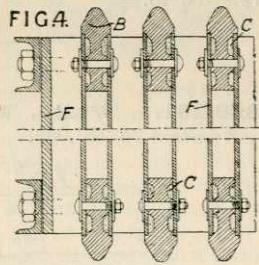

transversely of the corrugations being offset, the plates of each element being welded along the ridges of their corrugations, and adjacent elements being connected together along the off-

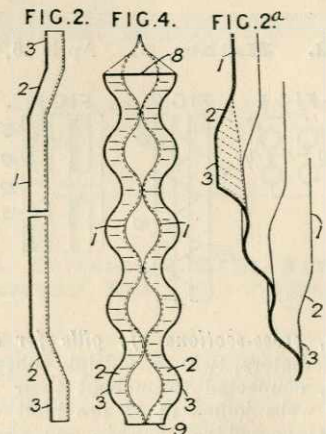

327,156. Howden & Co., Ltd., J., and Hume, J. H. Dec. 28, 1928.

Plate apparatus.—A heat exchanger comprises united pairs of corrugated plates 1, Figs. 2, 2^a, 4, the opposed edges 2, 3 of each plate extending

set edges. The gap formed by the offset parts on assembling the plates are closed by welded pieces 8, 9. The plates of an element may be corrugated lengthwise along waved lines. Specification 295,106 is referred to in the Provisional Specification.

327,377. Seligman, R. March 7, 1928,
[Convention date], Divided on 307,425.

Plate apparatus. — A heat-exchanger is made up of plates with facial grooves or ribs 1 which with a plain plate form zig-zag channels, the plates also having interiorly formed passages constituted by short baffles 17 leaving spaces 18 and 18¹ at each end. The plates may be divided through the middle of the baffles and the passages may be provided with spirals or the like to produce turbulence.

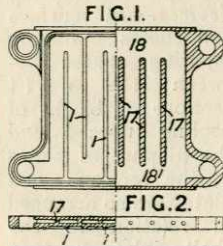

for welding to the headers, and may be formed of castings or pressings of non corrosive material such as an aluminium alloy.

327,398. British Electric Transformer Co., Ltd., and Thompson, J. L. Dec. 29, 1928.

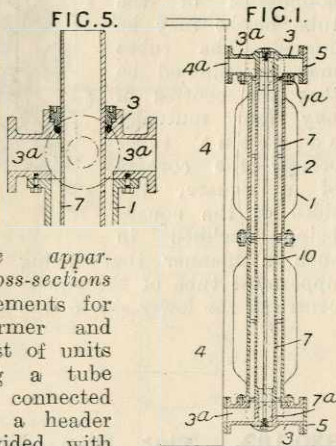

Concentric-tube apparatus; tubes, cross-sections of.—Radiator elements for electric transformer and like tanks consist of units each comprising a tube length 1, Fig. 1, connected at one end to a header member 3 provided with two or more lateral branches 3^a in the same plane, one of the branches being connected to the opening 4^a in the wall of the tank 4 and others connected to the branches of other similar headers or blanked off by plates 5. The lower end of the tube length may be connected to a similar header, or, as shown, to another tube having its header at the lower end. Thus any number of elements may be connected together in alignment or side by side for parallel flow of the liquid. The tubes may have longitudinal ribs 2, and may be fitted with internal concentric tubes 7 through which cooling air or liquid may be circulated. The headers may be formed with inner tube sections 7^a held by longitudinal bolts 10 against the inner tubes of the tube lengths, or, as shown in Fig. 5, the inner tubes may be continuous and extended upwards through stuffing-boxes, upward air currents being induced therein. Spiral baffles may be provided in the annular space between the tubes. The tubes may be flanged, or may have plain ends

328,076. Underfeed Stoker Co., Ltd., and Harlow, W. F. Feb. 26, 1929.

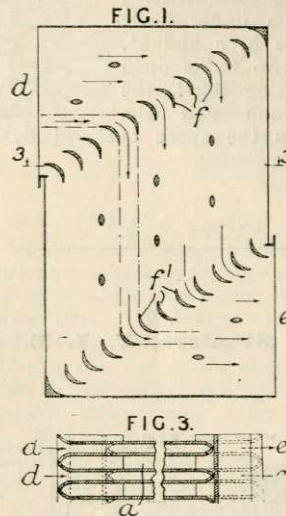
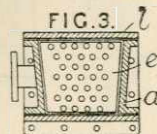

Plate apparatus. — In heat exchangers of the plate type in which alternate cells *a* have an entrance *d* on one face of the heater for one of the fluids concerned and an exit *e* on the opposite face for the other fluid, a change of direction of flow of the fluid is obtained by means of numerous deflectors *f, f'*, placed one at each position at which the change is to occur. The surface of each plate is ruled with parallel lines, which may be at right angles, and the deflectors of thickness equal to the width apart of the plates, welded or riveted to the plates at the points of intersection of the lines. The deflectors may be of crescent shape with faces which are circular arcs of different radii the arc of longer radius being tangential to the ruled lines. Knife edges are preferably used on the deflectors.

328,718. Hepworth, F. Feb. 21, 1929.

Straight tubes between headers; casings.—A heat exchanger is adapted for the lateral insertion and removal of the tube bundle without breaking the joints of conduits conveying fluid



to and from the apparatus. Tube-plates *e* of taper or wedge shape joined by tubes *f* are inserted into a casing *a* after removal of one side-wall *l*, and fluid-tight joints with the internal walls are made by packing material *h* which may be rubber cord in appropriate grooves, thus affording accommodation for expansion under heat. The conduits *b*, *c* and *b'*, *c'* for the two fluids open into the casing itself, the former beyond and the latter within the space enclosed by the tube-plates *e*.

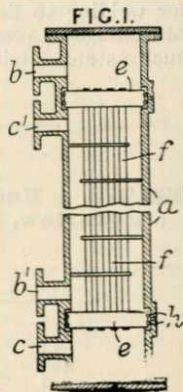

329,714. Stenfors, F. I. E. Feb. 26, 1929.

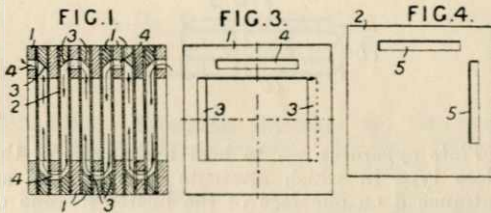
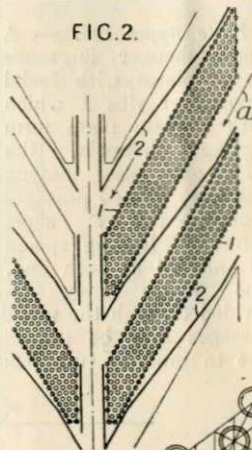

Plate apparatus.—A sectional heat interchanger for two fluids comprises apertured frames separated by apertured heat-conducting discs to form a number of cells equal to the number of frames and connected to form two series of channels at right angles. Each frame *1* has two slots *4* and a central substantially rectangular aperture with two opposite parallel bevelled edges *3*. Each disc *2* has slots *5* and may be corrugated. The frames are superposed each with its rectangular aperture at right angles to those adjacent, and the discs are similarly interposed to build up two series of connected channels of which one is shown in Fig. 1. The width of the slots is equal to the thickness of the frame. The disc and frame may be made in one piece. The frame may have raised ribs with lead or asbestos packing fitting grooves in adjacent frames. The partition between the cells may be formed with raised ribs on both sides in the direction of flow of the liquid.

329,975. Petty, T. Jan. 28, 1929.

Drip intercepting devices.—In surface condensers having tapering spaces between the unit sections or blocks of cooling tubes *1* and the diaphragm plates *2*, the sections and plates are so arranged in relation to the shell inlet *a* that the condensate falls across the convergent tapering space at the steam approach side and collects upon the diaphragm which guides the steam into the tube block.



The tube blocks and plates may be set at any angle to the horizontal and the boundaries of the tube blocks may be curved. The tubes may be pitched so that the centres of any four mutually adjacent tubes occupy the corners of a square, the sides of the square being inclined in such a manner that falling drops from the uppermost tube of the square pass through the centre of the lower side of the square.

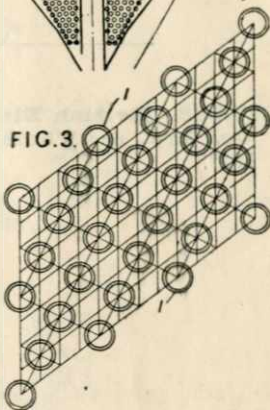

330,183. Fiat Soc. Anon. June 7, 1929, [Convention date].

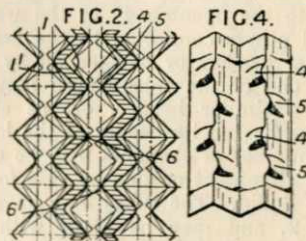
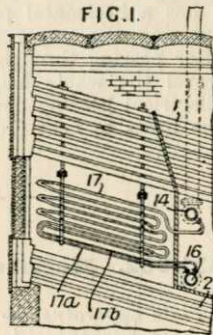

Plate apparatus.—The corrugated strips *1*, *1'* of a motor-car &c. radiator are formed with transverse projections *4*, *5* which project into the air passages of the radiator and produce whirling of the air passing therethrough. The projections extend slightly beyond the edges *6*, *6'* of the strips so that when the edges abut the projections prevent relative longitudinal displacement of the strips.

330,385. Superheater Co., Ltd., (Superheater Co.). May 16, 1929.

Loop tube apparatus.
—In a unitary tubular element of multi-loop type for use in heat exchange, the outlet portion loop or loops is or are formed of pipe having an internal diameter or cross-sectional area less than that of the rest of the piping. In the form shown, the elements are bifurcated near to their outlet ends, tubes 17a, 17b of smaller diameter connecting the bifurcation with an outlet header 16. The combined cross-sectional area of the tubes 17a, 17b may be less or greater than or equal to that of the tube 17. In another form, the elements 17 are reduced in diameter for the last loop instead of being bifurcated. The tubes may be joined by the processes described in Specifications 6304/15 and 120,042, [both in Class 99 (i), Pipes and tubes, Joints &c. for].



helically on one edge, the discs &c. are cut to form a series of tongue like pieces which are bent alternately in opposite directions. In the case of a disc 2, Fig. 1, radial cuts divide it into sectors 3 which are alternately bent, upwards and downwards, and by using discs 6 having a pressed-out part 7 the heat exchange tube may be formed by assembling discs as shown in Fig. 12. In the

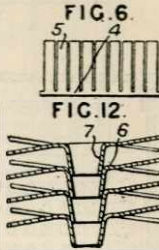
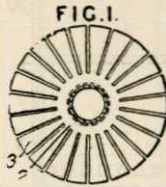

case of a strip 4, Fig. 6, parallel cuts may be formed in it, thus facilitating the winding of the strip edgewise on a heat exchanger tube and furnishing parts 5 which are bent alternately in opposite directions. The strip may also be formed with parallel slits across its centre part, and can then be bent up into a U-shaped section and attached to the heat exchange tube by its edges, alternate strips being bent in opposite directions. Parallel slits may be formed on the sides of the strip which is bent up into a U-shaped section and attached to the tube along its centre portion, the projections being bent as before.

330,590. Owen, W. H. March 12, 1929.

Tubes, cross-sections of; straight tube apparatus having internal baffles.—An air pre-heater of the cellular or tubular type is fitted with a deflector consisting of a length of coiled wire engaging the heat exchange surface. A tube 1 of an exit heater is shown fitted with an internal spiral 2 and an external spiral 3. In cellular apparatus a rectangular spiral 6 is used. The deflectors are resilient and friction is principally relied on to keep them in place. Specification 228,218, [Class 64 (i), Heating liquids &c.], is referred to.

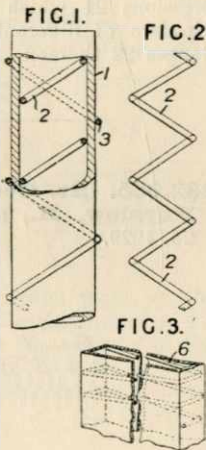

331,602. Heenan & Froude, Ltd., and Walker, G. H. Jan. 10, 1930.

Straight-tube apparatus having internal baffles; plate apparatus.—In heat exchanging apparatus one or more cores are interposed in the path of the moving fluid, the cores being formed of a metal ribbon or strip F which is slit and the parts f between the slits twisted so that they will lie at an angle to the flow of the moving fluid. The latter is thereby caused to take a tortuous passage and prevented from forming stream lines during its passage in contact with or in proximity to the heat transmitting surface. Three or more such ribbons may be used, the segments f being then staggered in relation to those of an adjacent ribbon. The segments may be twisted at an angle to the general path of the fluid flow and also to each other and further, also offset relatively to each other. The core or cores may be inserted in tubular or plate apparatus.

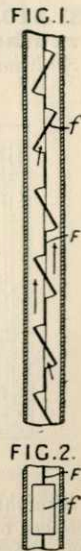

331,392. Payne, M. July 4, 1929.

Tubes, cross-sections of.—In tubular heat exchangers in which the tubes are covered with annular discs, or lengths of strip material wound



331,778. **Johannsson, P.** Oct. 7, 1929.

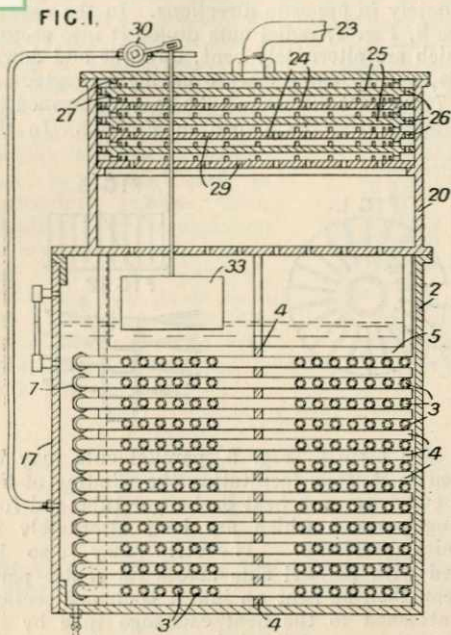

Coil-tube apparatus.—An evaporator for boiler feedwater comprises a tank 2 with heating coils 3 through which passes waste steam superheated in the boiler flue. The coils are spaced by spiders 4, are held by a cage-like frame 5, and are connected to inlet and outlet headers as at 7. A cleaning door 17 is arranged between the two headers.

conducting contact with the pipes. The plate *c* is flanged at *d* and the plate *e* at *f* and the contacting edges are welded. The discharge header *a* has a horizontal partition *g*, by which steam entering the upper header as a heating fluid, after passing through the tubes, is compelled to travel the whole length of the lower header. Electrical heating devices may be fitted between the tubes to heat fluid in the tubes.

331,982. **Harrison, J. M.** May 13, 1929.

Plate apparatus.—A heat exchanger is formed of several elements each consisting of two parallel sheet metal plates 10 spaced apart by filler strips 12, 13 secured between their edges, spacers 19 between the elements, and inlet and discharge headers 17, 18 extending transversely of the elements and welded to the spacers and edges of the elements. The headers 17, 18 communicate with the interior of the element by openings 15 between the filler bars 12, 13. The filler strips and blocks are welded to the elements, each of which may be formed from a single bent sheet 11 provided with depressions 21 which may be welded together. Headers of different units may be joined by flanges 22 thereon.

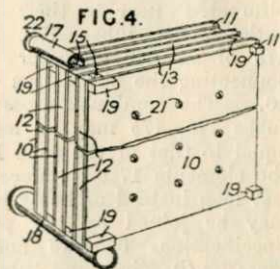

331,910. **Kränzlein, G., and Samesreuther & Co., Ges.** April 9, 1929.
Addition to 309,445.

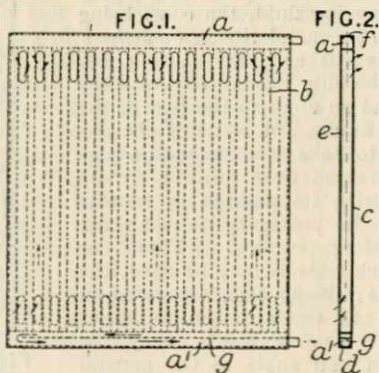

Straight tubes between headers.—The heat-exchanger of the parent Specification is modified in that the pipes *b* and headers *a*, *a'* are enclosed within two flanged plates *c*, *e* which are in heat-

332,065. **St. George's Engineers, Ltd., Purslow, H., and Anderson, J.** July 25, 1929.

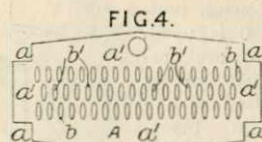

Headers.—In a header for a radiator or cooler constructed from a flat blank *A* punched with tube apertures *b* the corners *a* of the blank are cut out leaving members *a'* which are bent at right angles into box form to comprise the sides, ends and tube plate, the header being completed by a flat outer face plate *c*, Fig. 1, welded to the edges; the tubes *B* are welded into the tube plate before the outer plate is attached. The tube plate may also contain apertures *b'* to take

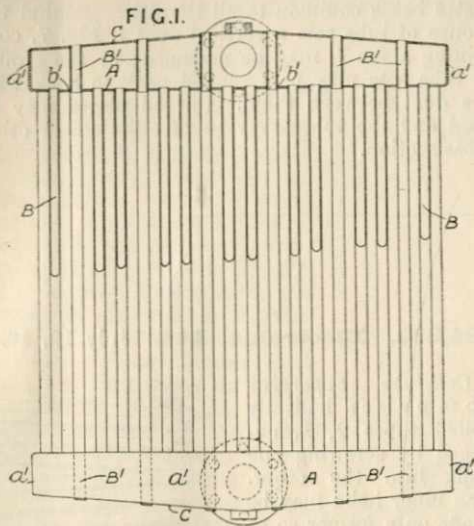

straight or conical tubes B' for air passages. The tubes and apertures may be of elliptical or other cross-section. Specification 254,600 is referred to.

332,280. Kochs & Co., Ltd., W. E., (Föge, H.). April 17, 1929.

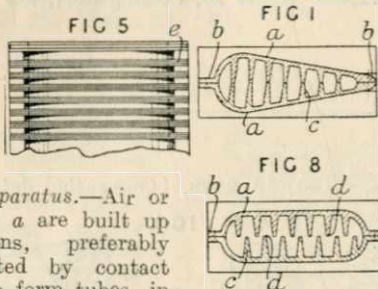

Plate apparatus.—Air or gas heaters *a* are built up in sections, preferably halves united by contact flanges *b* to form tubes, in which internal ribs *c* are provided extending to the medial plane of the pipe. External ribs *e* lie at right-angles to the internal ribs *c*. In Fig. 8 the free edges *d* of the ribs are displaced with regard to those of other halves. The tubes may be pear-shaped or parallel-sided in cross section.

332,455. Junkers, H. Oct. 26, 1928, [Convention date].

Tubes, cross-sections of; gills for tubes.—Gills 2 in heat exchanging apparatus are provided with baffles 3, 4, and 5 to retard the flow of heat exchange medium over the gills and to direct it on to channels 1 conveying the other medium. The baffles may decrease in height or be otherwise

shaped to offer less resistance in the parts adjacent to the channels 1. Bulges in the gills may form the baffles which may be offset as in

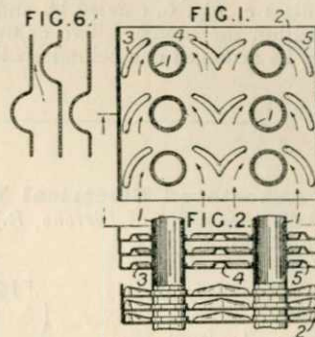
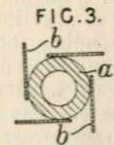

Fig. 6, or gills with double bulges may alternate with plain gills; lugs may also constitute the baffles.

332,838. Talbot, W. J., and Talbot-Stead Tube Co., Ltd. Oct. 18, 1929.

Gills for tubes.—The heat radiating surface of a Perkins' tube *a* is increased by fins in the form of longitudinal strips *b* attached to the tube near one edge so as to project tangentially as shown. Specification 22579/00 is referred to.



333,764. Serck Radiators, Ltd., and Wagner, C. O. Sept. 5, 1929.

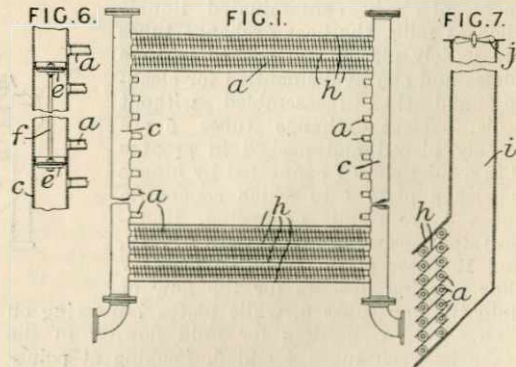

Straight tubes between headers or connecting-boxes.—In apparatus comprising gilled tubes *a* through which liquid flows, inclined plates *h* are placed between and preferably in contact with adjacent gills, so as to form upwardly inclined



Messages for air or other gas over the tubes. The tubes connect at their ends with vertical headers *e*. Circuitous flow of liquid through the tubes may be obtained by partitioning the headers with metal discs *e*, Fig. 6, carried by and spaced on a rod *f* within the header. Two or more sets of tubes may be arranged one behind another, the

plates being common to all the sets. Behind the groups of tube sets a vertical duct *i*, Fig. 7, containing a fan *j*, may be arranged; or the groups of tube sets may be arranged back to back with the duct between them. Curved plates may be used and the tubes may be of elliptical or other cross-section.

334,127. Associated Electrical Industries, Ltd., (Assignees of *Bierens, R.*). Nov. 9, 1928, [Convention date].

Headers.—A radiator is constructed by forming riser members 1 from two flat metal plates welded together at their edges 3, and if desired at intermediate lines 4, and then deformed as described in Specification 304,689, [Class 64 (ii), Heating systems &c.], welding the edges of the openings to corresponding openings 6, Fig. 3, in a plate 5 of trough-like section, and then bending the sides of the troughs and welding their edges together so as to form headers uniting the ends of the riser members. The apparatus may be used for electrical transformer coolers.

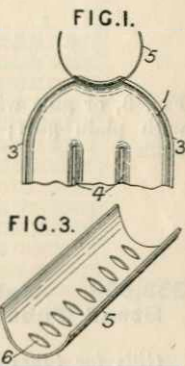

334,333. Electrolux, Ltd. July 19, 1929.

Coil-tube apparatus comprises helically coiled tubes 2, 1, engaged by screwing one helix into the other. The inner helix may be made on a former so as to have an external diameter larger than the diameter of the grooves of the outer helix, to secure metallic contact by pressure between the turns. The contact may be increased by tinning, or by spray casting or otherwise depositing metal around the surfaces. Where a copper tube for cooling-water and an iron tube for ammonia are used, the copper tube is preferably arranged within the iron tube. Specifications 275,188; and 292,480, [Class 29, Cooling &c.], are referred to.

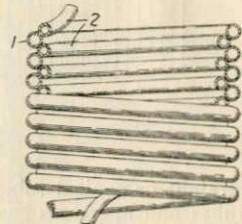

335,395. Bergedorfer Eisenwerk Akt.-Ges. Oct. 19, 1928, [Convention date].

Concentric straight-tube apparatus.—In a heat exchanger for the treatment of easily contaminated liquids such as milk, the heat exchange tubes are loosely placed and packed in tube plates and can be dismantled for cleaning and then reassembled without tools. Heat exchange tubes 5 are loosely placed and packed in grooves 9 in a tube plate 7 connected by hinges 8 with a plate 1 to which concentric tubes 4 are rigidly connected. Hand-operated screw-closing devices 17, 18, and 19 press plates 15 on to plates 7 thus forming headers for the flow of fluid through tubes 5, while plates 7 pressing on plates 1 form headers for fluid flowing in the space between tubes 4 and 5. Packing at points 14 and 16 render all joints tight and spreaders 6 are provided in tubes 5 to improve the heat

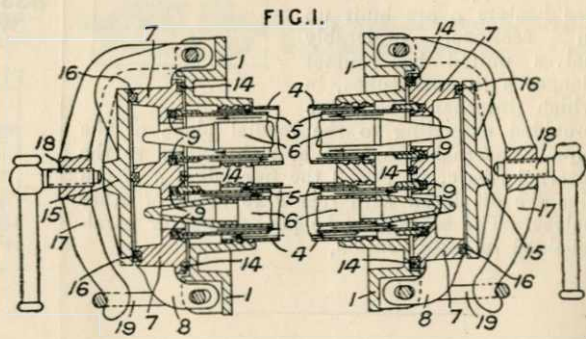

exchange. On unscrewing the closing devices, plates 7 can be swung open on their hinges and tubes 5 and spreaders 6 withdrawn and cleaned; and the inside surfaces of tubes 4 can also then be cleaned with tube brushes.

336,355. Soc. des Condenseurs Delas. June 17, 1929, [Convention date].

Straight tubes between headers or connecting-boxes.—

In a condenser of the type in which a cross section of the water tubes in a plane normal to their axis is limited by an upper outline having tubeless spaces I, II, III converging to the bottom and a lower outline having tubeless spaces I', II', III', and IV' diverging to the bottom as described in Specification 241,776, the upper spaces are open at their lower ends which are obstructed by baffles 5, 6 and 7. Baffles 21 - - 24 may be provided on the upper points of the top outline. When the tubes are arranged as in Fig. 3 so that water dripping from one tube falls tangentially on the tube below, the sides of the baffles 5, are arranged parallel to the inclined rows of tubes. In Fig. 5 a condenser is shown in which multiple paths for the water are provided necessitating spaces 16 free from tubes opposite ribs in the headers.

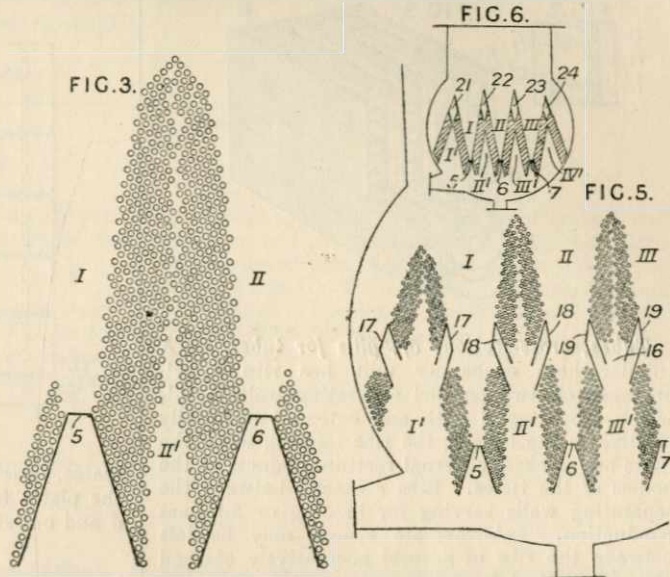

In this case additional baffles 17, 18 and 19 are provided to avoid disturbance of the flow of steam.

336,755. Howden & Co., Ltd., J., and Hume, J. H. Sept. 21, 1929.

Straight tubes between headers.—

In a heat exchanger comprising rows of parallel tubes 1, the spaces between the tubes of each row are filled with metallic pieces 2 formed with concave surfaces on their exposed sides as well as on their sides in contact with the tubes, so as to direct the heating gases or other fluid in continuously sinuous paths between the tubes.

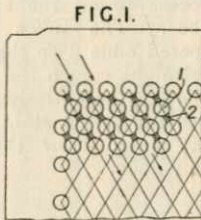

The plate 36 has grooves 39 which connect the upper three tubes with the lower three. The front ends of five of the tube systems are, together with jackets 34, secured in a wall 38 having grooves 40 for connecting the three bottom tubes in one tube system with the three top tubes in the next system, and with grooves 41 for connecting the jacket 34. The grooves 39, 40 are

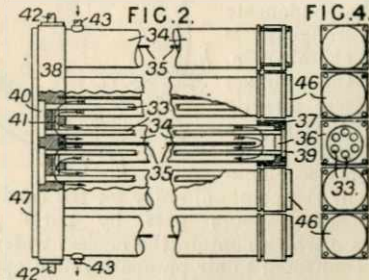

covered by plates 46, 47 respectively. The partitions 35 are spaced from plates 36, thus providing a U-shaped channel in each jacket for the heating liquid. The inlets and outlets 42 for the milk are situated at the wall 38, and those 43 for the hot water on the wall 38 or the end jackets 34. The grooves 39, 40 may alternatively be arranged to connect the tubes in pairs, or to connect a pair of tubes to another pair. The partitions 35 may, in other forms, be star, cross, &c., in section so as to divide the jackets up into compartments containing one or more tubes.

337,027. Nielsen, N. J. June 27, 1929.

Jacketed straight-tube apparatus.— A heat exchanger for use in sterilizing milk &c. under pressure consists of a series of units VI each comprising six tubes 33, through which the milk &c. is passed, surrounded by a jacket 34 and placed three on each side of a partition 35. The heating liquid is passed through the jacket 34. The rear ends of the tubes 33 are fixed in a plate 36 secured removably and liquid-tight by a tightening ring 37 to the jacket 34.



337,236. **Hubert, C. A.** Nov. 22, 1929.

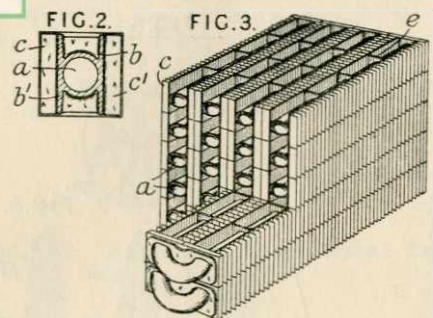

Tubes, cross-sections of; gills for tubes. — A tubular heat exchanger unit has ribs *c*, *c'*, arranged on two parallel separating walls *b*, *b'*, which are integral with and extend tangentially relative to the tube *a*, the ribs forming when the units are stacked, external rectilinear ducts at the bodies of the tubes. Ribs *c* extend between the separating walls serving for bracing or for heat conduction. Intermediate spaces may be left between the ribs of several successively stacked rows in vertical lateral order.

337,631. **International General Electric Co., Inc.**, (Assignees of *Allgemeine Elektrizitäts-Ges.*). Nov. 28, 1928, [Convention date].

Longitudinal baffles, arrangements of. — In a surface condenser *a* provided with a baffle *b* which causes the condensate to flow through ports *d* into chamber *c*, part of the exhaust steam passes directly through the gap *e* in the water tubes and enters the chamber *c* below the points of entry for the condensate. Uncondensed vapours pass by ports *j* into chambers *g* which contain the coolest water tubes and are connected to air pumps through apertures *h*. Any vapour condensed in chamber *g* flows through openings *i* to the chamber *c*.

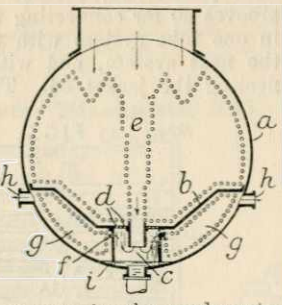

338,097. **Soc. of Chemical Industry in Basle.** April 29, 1929, [Convention date].

Plate apparatus. — In a hollow plate apparatus for heating rooms, drying, and evaporating liquids, the heating surfaces consist of plates *p*

connected by bars *c* inserted through perforations in inwardly projecting ribs *b* carried by the

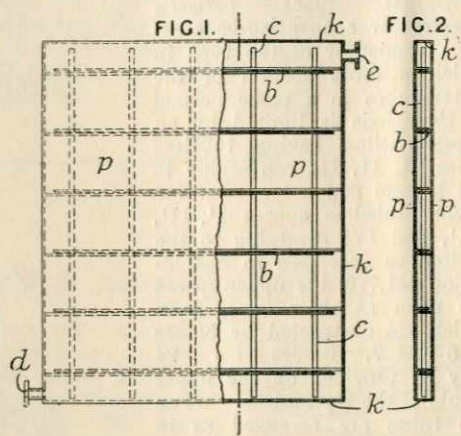

plates. Strips *k* are welded round the edges of the plates to complete the chamber and an inlet *d* and outlet *e* are provided.

338,685. **Lande, B. L. M. van der.** Sept. 7, 1929, [Convention date].

Headers. — A radiator consists of a number of tubes *1* directly secured in headers *2* by casting the latter as a whole in one process round the ends of the tubes. The tubes may have tapered ends *3* so that by using a straight core *6* the end of the tube may be entirely surrounded with the cast metal. The tubes may have screw threads *5* at their ends.

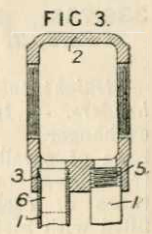

338,818. **Johnson, J. Y.**, (*I. G. Farbenindustrie Akt.-Ges.*). Feb. 13, 1930.

Materials. — Apparatus for exchanging heat between two fluids comprises a composite block formed of plates of good thermal conductivity alternating with plates of bad thermal conductivity, the fluids traversing respectively alternate borings in the block. The layers of bad conductivity reduce the heat loss in the direction of flow of the fluids. Good conducting plates such as copper, aluminium, *a*¹ - alternate with bad

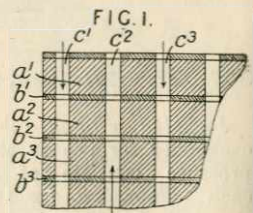

conducting layers such as asbestos, mica, b^1 . . . The heat exchange fluids are passed through borings c^1 . . ., one fluid being passed through

alternate borings and the other fluid through the remaining borings in the opposite direction.

339,198. Superheater Co., Ltd., (*Superheater Co.*). Feb. 14, 1930. *Addition to 330,385. Drawings to Specification.*

Loop-tube apparatus.—In a looped-tube steam or other fluid heater having the outlet portion of the piping forming an element of reduced internal diameter, as described in the parent

Specification, the outlet portion is of greater wall thickness and, at the same time may be of the same external diameter as the rest of the piping of the element. The elements are manufactured as described in Specifications 6304/15 and 120,042, [both in *Class 99* (i), Pipes and tubes, Joints &c. for].

339,405. Schmidt'sche Heissdampf-Ges. Jan. 9, 1929, [*Convention date*].

Coil-tube apparatus.

—A chamber 1 containing coiled heating tubes 6 through which flows a heating medium such as superheated steam is divided by transverse partitions 13 with staggered openings to give the steam to be heated a sinuous path over the heating tubes. The tubes are connected in pairs to a distributor and collector 28, 32 at the ends of the casing. To facilitate removal of the coils, the distributor and collector of each pair are arranged out of alignment with one another and on the projections of the separate coils. Each distributor or collector passes through a sleeve 34 secured steam-tight in a cover of the chamber or formed integral therewith. The partitions are supported by vertical rods 15, 16, connected together in

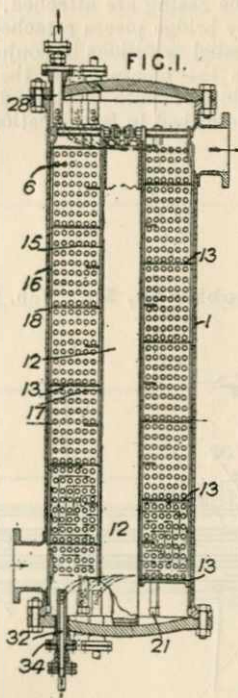

pairs and formed with lugs 17, 18 on which the partitions rest. The inner rods 15 are hooked over the upper end of a central closed cylinder 12, and the outer rods rest on projections 21 at the bottom of the chamber. Specification 138,870 is referred to.

339,835. C.B.A. Radiator & Engineering Co., Ltd., and Borns, R. E. G. Jan. 14, 1930.

Tubes, cross-sections of;

gills for tubes.—In a radiator consisting of a number of perforated and corrugated strips a, a^1, a^2, a^3 , &c. threaded over a number of parallel tubes b, b^1 , &c. between headers, the strips thus forming parallel air passages at right angles to the tubes, the tubes pass through perforations in the relatively inclined walls of the air passages. The assembled corrugated strips are fixed together by dipping the marginal portion into molten solder &c. To dispense with soldering, the assembled strips may be held together under compression between the headers by means of tubes attached at each end to the headers. Alternatively the whole radiator block or any part may be dipped into a bath of solder.

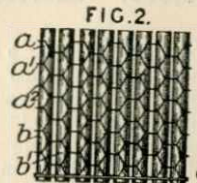

339,869. Morton & Co., Ltd., R., and Robinson, P. Feb. 7, 1930.

Straight tubes between headers.
—In surface apparatus consisting of units having a tubular casing 1 containing pipes 7, one fluid passing through the pipes and the other through the casing, and one or both fluids passing back and forth in the casing a number of times, the inner fluids flow back and forth in the unit in a sinuous path comprising a number of tubes connected in series so that the fluid flows in a single stream, the tubes being mounted in tube blocks 4 and 5 provided with passages directing the flow of the outer liquid over the tubes. The ends of the unit are provided with caps 6 containing recesses 20 - 23 which connect up the tubes 7 in series so that the inner liquid flows as indicated by the arrows in Fig. 12. The caps are carried by arms 25 hinged by a pin 26 to arms 27 carried by the casing and are pressed against the headers by a screw 30^a working in a bridge piece 28 attached by pins 26 and 29 to arms 27 and 30 on the casing. Ribs 18 on the tube blocks 4 and 5 fit into grooves 19 in the caps which are readily withdrawn to facilitate cleaning. The tube blocks themselves may contain the passages for connecting the tubes 7 in series in which case they are held in position by similar means to the caps. The casing 1 screws at each end into headers 2 and 3 provided with

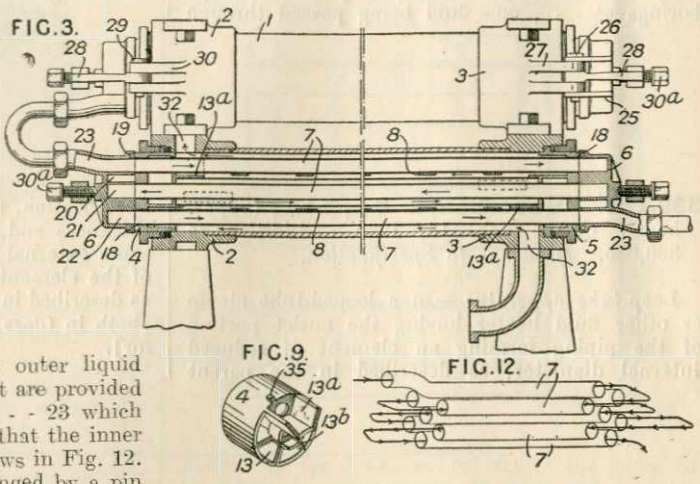

ports 32 for the outer fluid which contain the tube blocks 4 and 5. Keys 35, Fig. 9, prevent relative rotation between the blocks and headers. The tube blocks are provided with partitions 13, 13^a, and 13^b to which radial partitions extending along the casing are attached, the tubes 7 being carried by bridge pieces attached to these partitions. The radial partitions in conjunction with the partitions in the blocks cause the outer liquid to follow a sinuous path back and forth in the casing as described in Specification 339,870.

339,870. Morton & Co., Ltd., R., and Robinson, P. Feb. 7, 1930.

Straight tubes between headers.
—In surface apparatus comprising units consisting of tubular casings 1 containing tubes 7 extending longitudinally, one fluid flowing back and forth in the tubes and the other back and forth in the casing, the flow of the outer fluid is directed by partitions 9 arranged radially and dividing the casing into a number of passages. The partitions 9 are attached to blocks 4 and 5 which carry the tubes 7 and may be formed by longitudinal fins on a tube 10 enclosing the central tube 7 and provided with ports 31 to admit the outer fluid. Blocks 4 and 5 are provided with a central boss 12 connected to the periphery by radial partitions 13 to which the partitions 9 are attached. Partition 13^b does not extend to the end of the block, and partitions

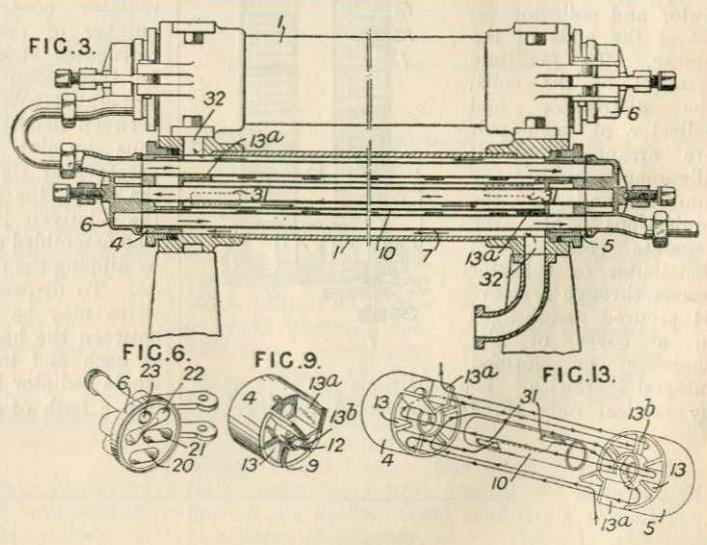

13^a extend forward from the block and are connected by an extension of the boss 12; a sector-shaped partition provided with an aperture for the tube 7 in the particular passage divides the space between partitions 13^a from the passages on each side and allows these two passages to communicate around the end of the middle passage. Thus the liquid entering by port 32 at the block 5 end is caused to flow as indicated by arrows in Fig. 13. Screw clamped caps 6 provided with depressions 20 - - 23 connect the tubes 7 in series. The blocks 4 and 5 may contain the connecting passages in which case they are held by screw clamping means similar to the caps. Specification 339,869 is referred to.

339,925. Babcock & Wilcox, Ltd., and Davy, C. H. May 14, 1930.

Straight tubes between headers. — Exhaust steam is re-heated in a casing 1 by high temperature live steam supplied to tubes 2

traversing the casing and connected to headers 3, 4. Exhaust steam passes downwards between the casing and a shell 12 around the tubes and then upwards among the tubes, finally passing through an outlet 15 at the top of the casing. The headers 3 are connected by transverse pipes 5 to a distributor 6 supplied with live steam through a pipes 7. The headers 4 are connected to a box 8 which is connected by a pipe 9 to a drum in which the water of condensation from the tubes collects. The tubes and headers are suspended from angle irons 24, secured to the upper and detachable portion of the casing. The exhaust steam is guided in a helical course around the shell 12 by a baffle 13.

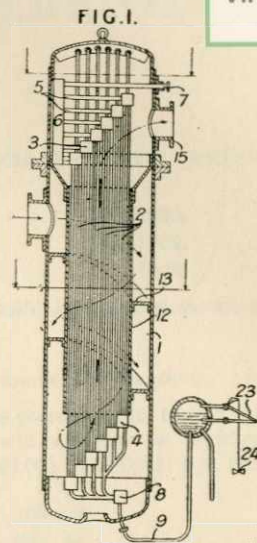



ILLUSTRATED ABRIDGMENTS OF SPECIFICATIONS

Published in three series as follows :—

Series (A.)—Classified in 146 volumes for each of the following periods dealing with all published specifications of the years 1855 to 1908 :—

1855-1866.	1884-1888.	1897-1900.
1867-1876.	1889-1892.	1901-1904.
1877-1883.	1893-1896.	1905-1908.

Series (B.)—Classified in 271 volumes for each of the following periods dealing with all published specifications of the years 1909 to 1930 :—

1909-1915.	1921-1925.
1916-1920.	1926-1930 (in course of publication).

Series (C.)—Classified in 40 Groups (one volume per Group), each Group volume corresponding to one or more of the Class volumes in Series (B.) and (A.). Each series of 40 Group volumes will comprise the Abridgments of 20,000 Specifications, and the first series will deal with Specifications Nos. 340,001 to 360,000 (i.e. the first 20,000 Specifications published in 1931).

	<i>Inland.</i>	<i>Abroad.</i>
Price per volume	2s. 0d.	2s. 4d.

The volumes for the period 1926-1930 and the Group volumes for Specifications 340,001-360,000, now in course of publication but not yet completed, can be obtained, sheet by sheet (16 pages) as printed, on payment in advance of a subscription for each volume of 5s. (inland), or 7s 6d. (abroad). The subscription for a complete set of advance sheets for the 40 Group volumes is £4 (inland), £4 10s. (abroad).

Series (A.)—List of Classes (1855-1908).	Corresponding Classes—Series (B) (1909-1930).	Corresponding Group Volume —Series (C) (1931 onwards).
1, ACIDS, ALKALIES, OXIDES, AND SALTS, IN-ORGANIC.	1 (i), Chemical processes and apparatus. (1909-15 out of print.) 1 (ii), Inorganic compounds other than metallic oxides, hydrates, oxyacids, and salts, (including Alkali manufacture and Cyanogen compounds). 1 (iii), Oxides, hydrates, oxyacids, and salts, Metallic, (other than Alkali manufacture and Cyanogen compounds).	III.
2, ACIDS AND SALTS, ORGANIC, AND OTHER CARBON COMPOUNDS, (including Dyes).	2 (i), Acetylene 2 (ii), Cellulose, Non-fibrous, and cellulose derivatives, (including Artificial filaments, sheets, and the like containing same). (1909-15 out of print.) 2 (iii), Dyes and hydrocarbons and heterocyclic compounds and their substitution derivatives.	IV.
3, ADVERTISING AND DISPLAYING	3 (i), Advertising and displaying apparatus, Moving and changing. 3 (ii), Advertising and displaying other than by moving and changing apparatus.	XVIII.
4, AERONAUTICS. (1905-8 out of print)	4, Aeronautics	XXXIII.
5, AGRICULTURAL APPLIANCES, FARMYARD AND LIKE, (including the housing, feeding, and treatment of animals).	5 (i), Farmyard and like appliances, (other than Housing and feeding animals). 5 (ii), Housing and feeding animals, (other than Chaff and vegetable cutters).	I.
6, AGRICULTURAL APPLIANCES FOR THE TREATMENT OF LAND AND CROPS, (including Gardening appliances).	6 (i), Cultivating implements and systems 6 (ii), Gardening and like appliances, (including Miscellaneous agricultural appliances). 6 (iii), Harvesting-appliances	I.
7, AIR AND GAS ENGINES. (1889-1892, 1897-1908 out of print).	7 (i), Combustion-product and hot-air engines. (1909-15 out of print.) 7 (ii), Internal-combustion engines, Arrangement and disposition of parts of, (including Construction of parts peculiar to internal-combustion engines). 7 (iii), Internal-combustion engines, Carburetting-apparatus, vaporizers, and heaters for. 7 (iv), Internal-combustion engines, Igniting in 7 (v), Internal-combustion engines, Starting, stopping, and reversing. 7 (vi), Internal-combustion engines, Valves and valve gear for, (including Other means and methods for regulating and controlling internal-combustion engines).	XXVII
8, AIR AND GASES, COMPRESSING, EXHAUSTING, MOVING, AND OTHERWISE TREATING.	8 (i), Air and gases, Compressing, exhausting, and moving, (including Bellows and Vacuum and like dusting and cleaning apparatus). (1909-15 out of print.) 8 (ii), Air and gases, Treating otherwise than by compressing, exhausting, and moving.	XXVIII.



Series (A)—List of Classes (1855-1908).	Corresponding Classes—Series (B) (1909-1930).	Corresponding Group Volume —Series (C) (1931 onwards).
9, AMMUNITION, TORPEDOES, EXPLOSIVES, AND PYROTECHNICS.	9 (i), Ammunition and ammunition receptacles. (1909-15 <i>out of print</i> .)	XXI.
10, ANIMAL-POWER ENGINES AND MISCELLANEOUS MOTORS.	9 (ii), Torpedoes, explosives, and pyrotechnics... 10, Animal-power engines and miscellaneous motors	XXVI.
11, ARTISTS' INSTRUMENTS AND MATERIALS ...	11, Artists' instruments and materials	XV.
12, BEARINGS AND LUBRICATING-APPARATUS ...	12 (i), Bearings and bearing-surfaces 12 (ii), Lubricating passages, channels, reservoirs, and baths, and lubricating-cans. 12 (iii), Lubricators and lubricating bearing-surfaces, (<i>other than</i> Lubricating passages, channels, reservoirs, and baths).	XXXIV.
13, BELLS, GONGS, FOGHORNS, SIRENS, AND WHISTLES.	13, Bells, gongs, foghorns, sirens and whistles	XXXVIII.
14, BEVERAGES, (<i>excepting</i> Tea, coffee, cocoa, and like beverages).	14 (i), Aerating liquids, and gazogenes, seltzogenes, and siphon bottles. 14 (ii), Beverages, malt products, and organized ferments, (<i>other than</i> Aerating beverages).	VI.
15, BLEACHING, DYEING, AND WASHING TEXTILE MATERIALS, YARNS, FABRICS, AND THE LIKE, (<i>excepting</i> Dyes).	15 (i), Dyeing and otherwise treating textiles, textile materials, and the like with liquids and gases, Apparatus for, (<i>including</i> Bleaching and washing, Processes and materials for).	IV.
16, BOOKS. (<i>including</i> Cards and card cases and the like).	15 (ii), Dyeing, Processes and materials for 16, Books, mercantile forms, and the like	XV.
17, BOOTS AND SHOES	17 (i), Boots and shoes, Apparatus for making and repairing... 17 (ii), Boots and shoes, Construction of 17 (iii), Boots and shoes, Protectors and trees and other accessories for.	VII.
18, BOXES AND CASES. (<i>excepting</i> Trunks, portmanteaux, hand and like travelling bags, baskets, hampers, and other wickerwork).	18, Boxes and cases	XVII.
19, BRUSHING AND SWEEPING	19, Brushing and sweeping	XXIII.
20, BUILDINGS AND STRUCTURES	20 (i), Buildings and structures, Kinds or types of 20 (ii), Buildings and structures, Miscellaneous accessories and details applicable generally to. 20 (iii), Doors and windows and their accessories 20 (iv), Floors, roofs, walls, and ceilings	X.
21, CASKS AND BARRELS	21, Casks and barrels	XVII.
22, CEMENTS AND LIKE COMPOSITIONS	22, Cements and like compositions	V.
23, CENTRIFUGAL DRYING, SEPARATING, AND MIXING MACHINES AND APPARATUS.	23, Centrifugal machines and apparatus, (<i>other than</i> Centrifugal fans, pumps, and reels).	II.
24, CHAINS, CHAIN CABLES, SHACKLES, AND SWIVELS.	24, Chains, chain cables, shackles, and swivels	XXV.
25, CHIMNEYS AND FLUES, (<i>including</i> Ventilating-shaft tops).	25, Chimneys and flues, (<i>including</i> Ventilating-shaft tops). ...	X.
26, CLOSETS, URINALS, BATHS, LAVATORIES, AND LIKE SANITARY APPLIANCES.	26, Closets, urinals, baths, lavatories, and like sanitary appliances.	I.
27, COIN-FREED APPARATUS AND THE LIKE ...	27, Coin-freed apparatus and the like	XVIII.
28, COOKING AND KITCHEN APPLIANCES, BREAD-MAKING AND CONFECTIONERY.	28 (i), Bread-making, confectionery, and cooking-appliances. 28 (ii), Kitchen and like appliances other than cooking-appliances.	VI.
29, COOLING AND ICE-MAKING, (<i>including</i> Refrigerators and Ice-storing).	29, Cooling and ice-making, (<i>including</i> Refrigerators and Ice-storing).	XIII.
30, CUTLERY	30, Cutlery	XIV.
31, CUTTING, PUNCHING, AND PERFORATING PAPER, LEATHER, AND FABRICS, (<i>including</i> the general treatment of paper after its manufacture)	31 (i), Cutting and severing machines for paper, leather, fabrics, and the like. 31 (ii), Punching and perforating machines and hand tools for cutting, punching, perforating, and tearing paper, leather, fabrics, and the like.	VIII.
32, DISTILLING, CONCENTRATING, EVAPORATING AND CONDENSING LIQUIDS, (<i>excepting</i> Steam-engine condensers).	32, Distilling and evaporating liquids, (<i>including</i> Condensing vapours and Crystallizing).	III.
33, DRAINS AND SEWERS	33, Drains and sewers	I.
34, DRYING	34 (i), Drying gases, clothes, and materials in long lengths ... 34 (ii), Drying systems and apparatus, (<i>other than</i> Drying gases, clothes, and materials in long lengths).	XIII.
35, DYNAMO-ELECTRIC GENERATORS AND MOTORS, (<i>including</i> Frictional and influence machines, magnets, and the like).	35, Dynamo-electric generators and motors, (<i>including</i> Frictional and influence machines, magnets, and the like).	XXXV.
36, ELECTRICITY, CONDUCTING AND INSULATING	36, Electricity, Conducting and insulating	XXXVI.
37, ELECTRICITY, MEASURING AND TESTING ...	37, Electricity, Measuring and testing, (<i>including</i> Electric resistances and inductances). (1909-15 <i>out of print</i> .)	XXXVI.
	38 (i), Electric couplings, and cut-outs other than electro-magnetic and thermal.	XXXVI.
	38 (ii), Electric currents, Converting and transforming other than by rotary converters and rotary transformers, and condensers. (1909-15 <i>out of print</i> .)	XXXV.
	38 (iii), Electric motor control systems and motor and like controllers. (1909-15 <i>out of print</i> .)	XXXVII.
	38 (iv), Electric supply and transmission systems and apparatus not otherwise provided for.	XXXV.
	38 (v), Electric switches and electro-magnetic and thermal cut-outs, (<i>other than</i> Motor and like controllers).	XXXVII.
38, ELECTRICITY, REGULATING AND DISTRIBUTING.	39 (i), Electric lamps, Arc and incandescent-arc and vacuum or low-pressure apparatus for electric discharges through gases or vapours.	XL.
39, ELECTRIC LAMPS AND FURNACES	39 (ii), Electric lamps, Incandescent 39 (iii), Heating by electricity, (<i>including</i> Electric furnaces and ovens). (1909-15 <i>out of print</i> .)	XI.

Series (A)—List of Classes (1855-1908).	Corresponding Classes—Series (B) (1909-1930).	Corresponding Group, Volume —Series (C) (1931 onwards).
40, ELECTRIC TELEGRAPHS AND TELEPHONES. (1884-8 out of print.)	40 (i), Electric signalling systems and apparatus, (other than Telegraphs and Telephones). 40 (ii), Phonographs, gramophones, and like sound trans- mitting and reproducing instruments. 40 (iii), Telegraphs, Electric 40 (iv), Telegraphs and telephone systems and apparatus, Electric. 40 (v), Wireless signalling and controlling. (1909-15 out of print.)	XXXVIII. XL. XXXIX. XL.
41, ELECTROLYSIS, (including Electro-deposition and Electroplating).	41, Electrolysis, (including Electro-deposition and Electro- plating). (1909-15 out of print.)	XXXVI.
42, FABRICS, DRESSING AND FINISHING WOVEN AND MANUFACTURING FELTED, (including Folding, Winding, Measuring, and Packing).	42 (i), Fabrics, Finishing and dressing. 42 (ii), Fabrics, Treating otherwise than by finishing and dressing.	VIII.
43, FASTENINGS, DRESS, (including Jewellery)....	43, Fastenings, Dress, (comprising Buckles, Buttons, Jewellery, and certain other fastenings specially applicable to wearing apparel).	VII.
44, FASTENINGS, LOCK, LATCH, BOLT, AND OTHER (including Safes and strong-rooms).	44, Fastenings, Lock, latch, bolt, and other, (including Safes and strong-rooms).	XXV.
45, FENCING, TRELLIS, AND WIRE NETTING ...	45, Fencing, trellis, and wire netting	I.
46, FILTERING AND OTHERWISE PURIFYING LIQUIDS.	46, Filtering and otherwise purifying liquids	I.
47, FIRE, EXTINCTION AND PREVENTION OF ...	47 (i), Fire-escapes and fire and temperature alarms	XXI.
48, FISH AND FISHING	47 (ii), Fire-extinguishing and fire preventing and minimizing	XXI.
49, FOOD PREPARATIONS AND FOOD-PRESERVING	48, Fish and fishing	XXI.
50, FUEL, MANUFACTURE OF	49, Food preparations, food preserving and the like	VI.
51, FURNACES AND KILNS, (including Blowpipes and blowpipe burners; Smiths' forges and rivet hearths; and Smoke and fumes, Treating).	50, Fuel, Manufacture of	VII.
52, FURNITURE AND UPHOLSTERY	51 (i), Furnaces and kilns, Combustion apparatus of, (in- cluding Details in connection therewith).	XII.
53, GALVANIC BATTERIES	51 (ii), Furnaces and kilns for applying and utilizing heat of combustion, (other than Combustion apparatus and details in connection therewith).	XII.
54, GAS DISTRIBUTION	52 (i), Furniture, Fittings and details applicable generally to, and articles of furniture not otherwise provided for.	XII.
55, GAS MANUFACTURE	52 (ii), Furniture for sitting and lying upon	XII.
56, GLASS	52 (iii), Tables, desks, and leaf turners and holders	XII.
57, GOVERNORS, SPEED-REGULATING, FOR EN- GINES AND MACHINERY.	52 (iv), Upholstery, wall furniture, screens, and looking- glasses.	XIV.
58, GRAIN AND SEEDS, TREATING, (including Flour and meal).	52 (v), Window, stair, and like furniture, brackets, racks, and stands, (including Antinacassars and Table and like covers).	XIV.
59, GRINDING, CRUSHING, PULVERIZING, AND THE LIKE.	53, Galvanic batteries	XIV.
60, GRINDING OR ABRADING, AND BURNISHING ...	54, Gas distribution	XIV.
61, HAND TOOLS AND BENCHES FOR THE USE OF METAL, WOOD, AND STONE WORKERS.	55 (i), Coking and gas-producers	XIV.
62, HARNESS AND SADDLERY	55 (ii), Gas manufacture other than gas-producers and retorts	XIV.
63, HATS AND OTHER HEAD COVERINGS	56, Glass	XIV.
64, HEATING, (excepting Furnaces and kilns; and Stoves, ranges and fireplaces).	57, Governors, Speed-regulating, for engines and machinery...	XIV.
65, HINGES, HINGE-JOINTS, AND DOOR AND GATE FURNITURE AND ACCESSORIES, (excepting Fastenings, Lock, latch, bolt, and other).	58, Grain and seeds, Treating, (including Flour and meal) ...	XIV.
66, HOLLOW-WARE, (including Buckets, Pans, Kettles, Saucepans, and Water-cans).	59, Grinding, crushing, pulverizing, and the like	XIV.
67, HORSESHOES	60, Grinding or abrading, and burnishing	XIV.
68, HYDRAULIC ENGINEERING	61 (i), Hand-tool, brush, mop, and like handles	XIV.
69, HYDRAULIC MACHINERY AND APPARATUS, (excepting Pumps and other means for raising and forcing liquids).	61 (ii), Hand tools, (other than Wrenches and bolt, nail, screw, and like inserting and extracting tools and Boring and drilling tools).	XIV.
70, INDIA-RUBBER AND GUTTA-PERCHA, (including Plastic compositions and Materials of con- structive utility, other than metals and stone).	61 (iii), Wrenches and bolt, nail, screw, and like inserting and extracting tools.	XIV.
	62, Harness and saddlery	XIV.
	63, Hats and other head coverings	XIV.
	64 (i), Heating liquids and gases.	XIV.
	64 (ii), Heating systems and apparatus, (other than Heating liquids and gases and Surface apparatus for effecting trans- fer of heat).	XIV.
	64 (iii), Surface apparatus for effecting transfer of heat, (other than Apparatus in which the heat is transferred from products of combustion).	XIV.
	65 (i), Door and gate operating-appliances, furniture and accessories, (other than Fastenings, Lock, latch, bolt, and other and Hinges and pivots).	XIV.
	65 (ii), Hinges and pivots.	XIV.
	66, Hollow-ware, (including Buckets, Pans, Kettles, Sauce- pans, and Water cans)	XIV.
	67, Horseshoes	XIV.
	68 (i), Excavating earth and rock, booms, buoys, canals and rivers, ferries, and water supply.	XIV.
	68 (ii), Subaqueous buildings and structures, diving, and raising sunken ships and objects.	XIV.
	69 (i), Hydraulic apparatus not otherwise provided for ...	XIV.
	69 (ii), Hydraulic presses, meters, motors, and like apparatus for use with high pressures.	XIV.
	69 (iii), Spray-producers and liquid-distributing sprinklers and nozzles.	XIV.
	70, India-rubber and gutta-percha, (including Plastic com- positions and Materials of constructive utility other than metals and stone).	XIV.

Series (A)—List of Classes (1855-1908).	Corresponding Classes—Series (B) (1909-1930).	Corresponding Group Volume —Series (C) (1931 onwards).
71, INJECTORS AND EJECTORS	71, Injectors and ejectors	XXVIII.
72, IRON AND STEEL MANUFACTURE	72, Iron and steel manufacture	II.
73, LABELS, BADGES, COINS, TOKENS, AND TICKETS.	73, Labels, badges, coins, tokens, and tickets	XV.
74, LACE-MAKING, KNITTING, NETTING, BRAIDING, AND PLAITING.	{ 74 (i), Braid and braiding-machines, crochet, lace and lace-making, and net-making machines... ..	VIII.
	{ 74 (ii), Knitting and knitted fabrics.	
	{ 75 (i), Burners and burner fittings.	
75, LAMPS, CANDLESTICKS, GASALERS, AND OTHER ILLUMINATING-APPARATUS, (excepting Electric lamps).	{ 75 (ii), Lamp chimneys, globes, lenses, shades, reflectors and smut-catchers, and holders therefor.	XI.
	{ 75 (iii), Lamps for lighting and heating, Details and accessories applicable generally to, (including Lighting burners, pipes, cigars, and the like).	
	{ 75 (iv), Lamps for lighting and heating, Kinds or types of, (including Lighting, Systems of).	
76, LEATHER, (including Treatment of hides and skins).	76, Leather, (including Treatment of hides and skins) ...	VIII.
77, LIFE-SAVING, (MARINE), AND SWIMMING AND BATHING APPLIANCES.	77, Life-saving, (Marine), and swimming and bathing appliances.	XXI.
	{ 78 (i), Conveyors and elevators for dealing continuously with articles and materials in bulk.	
	{ 78 (ii), Lifting, lowering, and hauling not otherwise provided for.	
78, LIFTING, HAULING, AND LOADING, (including Lowering, winding, and unloading).	{ 78 (iii), Lifts, hoists, and jacks.	XXX.
	{ 78 (iv), Loading and unloading, (including Transporters and cranes).	
	{ 78 (v), Winding and paying-out apparatus for lifting, lowering, and hauling, (including Pulley-blocks and the like).	
	{ 79 (i), Locomotives and tramway, traction, portable and semi-portable engines.	
	{ 79 (ii), Motor-vehicles, Arrangement and disposition of driving, transmission, balance, and reversing gearing on.	
79, LOCOMOTIVES AND MOTOR VEHICLES FOR ROAD AND RAIL, (including Portable and semi-portable engines).	{ 79 (iii), Motor vehicles, Arrangement and disposition of parts of, not otherwise provided for, (including Construction of parts peculiar to motor vehicles).	XXXI.
	{ 79 (iv), Motor vehicles, Frames and under-carriage work of.	
	{ 79 (v), Motor vehicles and locomotives, Steering and controlling.	
	{ 80 (i), Gearing, Belt, rope, chain, toothed and friction, and gearing for converting and conveying rotary or reciprocating motion.	
80, MECHANISM AND MILL GEARING. (1877-1883 out of print).	{ 80 (ii), Gearing, Variable-speed, differential, and reversing, and for stopping and starting, and shafting and its accessories.	XXIV.
	{ 80 (iii), Link-work, cams and tappets, and ratchet and screw-and nut gearing.	
	{ 80 (iv), Mechanism not otherwise provided for	
81, MEDICINE, SURGERY, AND DENTISTRY	81 (i), Disinfecting and deodorizing, and medical and like preparations.	VI.
	{ 81 (ii), Medical, surgical, and dental appliances.	
82, METALS AND ALLOYS, [excepting Iron and Steel manufacture].	{ 82 (i), Metals, Extracting and refining, and alloys.	II.
	{ 82 (ii), Washing granular, powdered, and like materials, and amalgamating, cleaning, coating, and granulating metals.	
	{ 83 (i), Casting and moulding metals.	
83, METALS, CUTTING AND WORKING	{ 83 (ii), Metal articles and forms, Combination apparatus and processes specially designed for producing and treating.	XXII.
	{ 83 (iii), Metals, Cutting.	
	{ 83 (iv), Metals, Working.	
84, MILKING, CHURNING, AND CHEESE-MAKING	84, Milking, butter-making, and cheese-making	I.
85, MINING, QUARRYING, TUNNELLING, AND WELL SINKING.	85, Mining, quarrying, tunnelling, and well-sinking	XXI.
86, MIXING AND AGITATING MACHINES AND APPLIANCES, [excepting Centrifugal machines and apparatus].	86, Mixing and agitating machines and appliances	II.
	{ 87 (i), Bricks, building and paving blocks, slabs, tiles, and pottery.	X.
	{ 87 (ii), Moulding, plastic and powdered substances, (including Casting substances other than metals and Presses, (Mechanical).	V.
88, MUSIC AND MUSICAL INSTRUMENTS	{ 88 (i), Musical instruments, Automatic.	XXXVIII.
	{ 88 (ii), Music and musical instruments other than automatic.	
	{ 89 (i), Bolts, studs, nuts, washers, and rivets.	
89, NAILS, RIVETS, BOLTS AND NUTS, SCREWS AND LIKE FASTENINGS.	{ 89 (ii), Hooks, nails, cotters, pins, staples, wedges, and wood-screws.	XXV.
	{ 89 (iii), Nailing and stapling and wire-stitching	
90, NON-METALLIC ELEMENTS	90, Non-metallic elements	VII.
91, OILS, FATS, LUBRICANTS, CANDLES, AND SOAPS	91, Oils, fats, lubricants, candles, and soaps. (1909-15 out of print.)	III.
	{ 92 (i), Ordnance and machine-gun carriages and mountings.	XXI.
92, ORDNANCE AND MACHINE GUNS	{ 92 (ii), Ordnance and machine-guns	
93, ORNAMENTING	93, Ornamenting	XV.
	{ 94 (i), Packing and wrapping-up for transit and storage, (including Baling).	
94, PACKING AND BALING GOODS	{ 94 (ii), Paper bags, sacks, wrappers, and the like, (including Making envelopes).	XVII.
	{ 95, Paints, painting, and the like	
95, PAINTS, COLOURS, AND VARNISHES	95, Paints, painting, and the like	III.
96, PAPER, PASTEBOARD, AND PAPIER MACHE ...	96, Paper, pasteboard, and papier mache	VIII.

Series (A)—List of Classes (1855-1908).	Corresponding Classes—Series (B) (1909-1930).	Corresponding Group Volume —Series (C) (1931 onwards).
97, PHILOSOPHICAL INSTRUMENTS, (<i>including</i> Optical, nautical, surveying, mathematical, and meteorological instruments).	97 (i), Optical systems and apparatus. (1909-15 <i>out of print</i> .) 97 (ii), Surveying, navigational, and astronomical instruments. (1909-15 <i>out of print</i> .)	XX.
98, PHOTOGRAPHY	97 (iii), Thermometers, meteorological and mathematical instruments, and miscellaneous philosophical instruments. 98 (i), Photographic cameras and auxiliary apparatus therefor. 98 (ii), Photographic processes and apparatus other than for taking photographs. (<i>including</i> Photographic plates, films, and papers).	XX.
99, PIPES, TUBES, AND HOSE	99 (i), Pipes and tubes, Joints and couplings for, (<i>including</i> Joints for tubular framework <i>and like</i> Wire and rod couplings and joints). 99 (ii), Pipes, tubes, and hose, (<i>other than</i> Joints and couplings for).	XXVIII.
100, PRINTING, LETTERPRESS AND LITHOGRAPHIC	100 (i), Feeding and delivering webs and sheets. 100 (ii), Printing processes and apparatus, (<i>other than</i> Type setting and composing). 100 (iii), Type making, setting, and composing, (<i>including</i> Type-bar-making machines). 100 (iv), Typewriters and like machines. 101, Now included in 100 (ii).	XVI.
101, PRINTING, OTHER THAN LETTERPRESS OR LITHOGRAPHIC.		
102, PUMPS AND OTHER MEANS FOR RAISING AND FORCING LIQUIDS, (<i>excepting</i> Rotary Pumps).	102 (i), Pumps, Reciprocating, for liquids, (<i>including</i> Steam-engine air-pumps <i>and</i> Combined pumps for liquids and gases). 102 (ii), Water and other liquids, and semi-liquids, Raising and forcing otherwise than by pumps.	XXVIII.
103, RAILWAY AND TRAMWAY VEHICLES	103 (i), Brakes and retarding apparatus 103 (ii), Rail and road vehicles, Details applicable generally to. 103 (iii), Railway and tramway vehicles, Accessories for. 103 (iv), Railway and tramway vehicles, Body details and kinds or types of. 103 (v), Railway and tramway vehicles, Draught, coupling, and buffing appliances for. 103 (vi), Railway and tramway vehicles, Undercarriage and underframe details of.	XXXIV.
104, RAILWAYS AND TRAMWAYS	104 (i), Railway and tramway crossings and points and switches. 104 (ii), Railway and tramway permanent way other than crossings and points and switches, and railway and tramway systems other than electric. 104 (iii), Railways and tramways, Electric, (<i>including</i> Electric traction).	XXX.
105, RAILWAY SIGNALS AND COMMUNICATING-APPARATUS.	105, Railway signals and communicating-apparatus	XXX.
106, REGISTERING, INDICATING, MEASURING AND CALCULATING, (<i>excepting</i> Signalling and indicating by signals).	106 (i), Calculating, counting, and cash-registering apparatus. 106 (ii), Dynamometers, gauges, measures of length, steam-engine and like indicators, and testing-apparatus. 106 (iii), Fares and admission-fees checking, revolution and speed indicators, and odometers. 106 (iv), Indicating, recording, and registering apparatus not otherwise provided for. 106 (v), Measured quantities delivering, measures of capacity, and sampling liquids.	XIX.
107, ROADS AND WAYS	107, Roads and ways	X.
108, ROAD VEHICLES	108 (i), Road vehicles, Body details and kinds or types of. 108 (ii), Road vehicles, Undercarriage details and draught appliances for.	XXXII.
109, ROPES AND CORDS	108 (iii), Springs and vibration-dampers	
110, ROTARY ENGINES, PUMPS, BLOWERS, EXHAUSTERS AND METERS. (1877-83 <i>out of print</i> .)	109, Ropes and cords 110 (i), Centrifugal and screw fans and pumps 110 (ii), Rotary engines, pumps, blowers, exhausters, and meters, (<i>including</i> Rotary pump plant).	XXV.
111, SEWAGE, TREATMENT OF, (<i>including</i> Manure).	110 (iii), Turbines and reaction-wheels and motor power plant	
112, SEWING AND EMBROIDERING	111, Sewage, Treatment of, (<i>including</i> Manure) 112, Sewing and embroidering	I.
113, SHIPS, BOATS, AND RAFTS, DIV. I... ..	113 (i), Ship and boat fittings and accessories, and pontoons and rafts.	VII.
114, ————— DIV. II.	113 (ii), Ships and boats, Kinds or types and structural details of.	XXXIII.
115, ————— DIV. III.	114, Ships, boats, and rafts, Propelling, steering, and manoeuvring.	XXXIII.
116, SHOP, PUBLIC-HOUSE, AND WAREHOUSE FITTINGS AND ACCESSORIES.	115, Ships, boats, and rafts, Rigging, sails, and spars for, (<i>including</i> Boat raising, lowering, and disengaging gear).	XXXIII.
117, SIFTING AND SEPARATING	116, Shop, public-house, and warehouse fittings and accessories.	XVIII.
118, SIGNALLING AND INDICATING BY SIGNALS, (<i>excepting</i> Railway signals and communicating-apparatus).	117, Sifting and separating	II.
119, SMALL-ARMS	118 (i), Indicators and burglar and like alarms 118 (ii), Signals, (<i>including</i> Marine signals)	XXXVIII.
120, SPINNING, (<i>including</i> the preparation of fibrous materials <i>and</i> the doubling of yarns and threads).	119, Small-arms 120 (i), Spinning, Preparation of fibrous materials for, (<i>including</i> Obtaining, opening, carding, and like treatment of fibres in general). 120 (ii), Spinning, twisting, and winding yarns and threads, (<i>including</i> Winding cords, wire, and the like.) 120 (iii), Yarns and threads and miscellaneous spinning accessories and processes and treatment of fibres.	XXI.
		IX.



Series (A)—List of Classes (1855-1908).	Corresponding Classes—Series (B) (1909-1930).	Corresponding Group Volume —Series (C) (1931 onwards).
121, STARCH, GUM, SIZE, GLUE, AND OTHER STIFFENING AND ADHESIVE MATERIALS.	121, Starch, gum, size, glue, and other stiffening and adhesive materials.	V.
122, STEAM-ENGINES, (including Details common to fluid-pressure engines generally).	122 (i), Engine and like cylinders, connecting-rods, cross-heads and guides, fly-wheels, piston-rods, and pistons. 122 (ii), Steam-engine distributing and expansion valves and valve gear and valve-actuating arrangements therefor. 122 (iii), Steam-engines, Kinds or types of and details not otherwise provided for, (including Steam and other fluid-pressure hammers and presses. 122 (iv), Steam-engines, Regulating or controlling, starting, stopping, and reversing. 122 (v), Stuffing-boxes and substitutes therefor, (including Packing therefor).	XXVI.
123, STEAM GENERATORS, (excepting Furnaces)...	123 (i), Liquid-level regulating, indicating, and registering, incrustation and corrosion preventing and removing, and door lids and covers for resisting fluid pressure.	XVIII.
124, STONE, MARBLE, AND THE LIKE, CUTTING AND WORKING.	123 (ii), Steam-generators 123 (iii), Steam separators and superheaters 124, Stone, marble, and the like, Cutting and working... ..	XIII. XXIII.
125, STOPPERING AND BOTTLING, (including Bottles, jars, and like vessels).	125 (i), Bottles, jars, and like vessels, (including Non-refillable bottles, jars, and vessels). 125 (ii), Bottles, jars, and like vessels, Filling, opening, and closing, (other than Stoppers, lids, covers, and capsules). 125 (iii), Stoppers, lids, covers, and capsules, Bottle, jar, and like.	XVII.
126, STOVES, RANGES, AND FIREPLACES	126, Stoves, ranges, and fire-places	XI.
127, SUGAR	127, Sugar	VI.
128, TABLE ARTICLES AND APPLIANCES	128, Table articles and appliances	XIV.
129, TEA, COFFEE, COCOA, AND LIKE BEVERAGES	129, Tea, coffee, cocoa, and like beverages	VI.
130, TOBACCO	130, Tobacco	XIV.
131, TOILET AND HAIRDRESSING ARTICLES, AND PERFUMERY.	131, Toilet and hairdressing articles, and perfumery	XIV.
132, TOYS, GAMES, AND EXERCISES	132 (i), Amusement and exercising apparatus other than games and toys. 132 (ii), Games 132 (iii), Toys	XV.
133, TRUNKS, PORTMANTEAUX, HAND AND LIKE TRAVELLING BAGS, BASKETS, HAMPERS, AND OTHER WICKERWORK.	133, Trunks, portmanteaux, hand and like travelling bags, baskets, hampers, and other wickerwork	XVII.
134, UMBRELLAS, PARASOLS, AND WALKING-STICKS.	134, Umbrellas, parasols, and walking-sticks	VII.
135, VALVES AND COCKS	135, Valves and cocks 136 (i), Cycle, velocipede, and like vehicle brakes, steering-mechanism, and miscellaneous accessories.	XXIX.
136, VELOCIPEDES, (1877-83 out of print.)	136 (ii), Cycle, velocipede, and like vehicle driving-mechanism, (including Human power driving mechanism for apparatus other than vehicles.) 136 (iii), Cycles, velocipedes, and like vehicles, Kinds or types and structural details of.	XXXI.
137, VENTILATION	137, Ventilation	X.
138, WASHING AND CLEANING CLOTHES, DOMESTIC ARTICLES, AND BUILDINGS.	138 (i), Washing and cleaning buildings and domestic articles other than clothes, and dry cleaning clothes and other absorbent materials. 138 (ii), Washing, mangling and wringing, ironing, and starching clothes.	X. XXIII.
139, WATCHES, CLOCKS, AND OTHER TIMEKEEPERS	139, Watches, clocks and other timekeepers	VIII.
140, WATERPROOF AND SIMILAR FABRICS... ..	140, Waterproof and like fabrics	XVIII.
141, WEARING-APPAREL	141, Wearing-apparel	VIII. VII.
142, WEAVING AND WOVEN FABRICS	142 (i), Looms, Driving, reversing, stopping, and starting, and loom-shedding mechanism and pattern cards, chains, surfaces, and the like. 142 (ii), Looms, Kinds or types of, and details not otherwise provided for. 142 (iii), Looms, Weft supplying, inserting, beating-up, cutting, doubling, and twisting-in.	IX.
143, WEIGHING-APPARATUS	143, Weighing-apparatus	XVIII.
144, WHEELS FOR VEHICLES, [excepting wheels for Locomotives and tramway and traction engines; Railway and tramway vehicles; and Toys]. (1877-83; 1893-96; 1901-04 out of print.)	144 (i), Wheels for vehicles, (other than Wheel tyres, Pneumatic and other elastic, and rims for use therewith). 144 (ii), Wheel tyres, Pneumatic and other elastic and rims for use therewith.	XXXIV.
145, WOOD AND WOOD-WORKING MACHINERY.	145 (i), Wood, Cutting, (other than Sawing)	XXIII.
146, WRITING-INSTRUMENTS AND STATIONERY, AND WRITING-ACCESSORIES, (including Educational appliances).	145 (ii), Wood, Working, (including Sawing) 146 (i), Filing paper and like sheets. 146 (ii), Stationery, wafers and seals, educational appliances, and ciphers and codes. 146 (iii), Writing-instruments, ink, and receptacles for writing-materials.	XV.

To supplement the information relating to the Group volumes of Abridgments given in column 3 above, a full list of the 40 Groups showing the Classes of the present classification covered by each Group is given below.

Group.	Corresponding Classes in existing Classification.
I. Agriculture. Fencing. Filtering. Sewage	5 (i-ii). 6 (i-iii). 26. 33. 45. 46. 58. 62. 67. 84. 111.
II. Metals and alloys. Mixing. Pulverizing. Separating	23. 59. 72. 82 (i-ii). 86. 117.
III. Chemistry, Inorganic. Distillation. Oils. Paints	1 (i-iii). 32. 90. 91. 95.
IV. Acetylene. Cellulose. Chemistry, Organic. Dyes and dyeing.	2 (i-iii). 15 (i-ii).
V. Cements. Indiarubber. Moulding, Non-metallic. Starch.	22. 70. 87 (ii). 121.
VI. Beverages. Food production. Medicine and surgery. Tobacco.	14 (i-ii). 28 (i-ii). 48. 49. 81 (i-ii). 127. 129. 130.
VII. Boots. Dress and dress fastenings. Nailing. Sewing.	17 (i-iii). 43. 63. 89 (iii). 112. 134. 141.
VIII. Fabrics. Laundering. Leather. Perforating and severing, Non-metallic. Waterproofing.	31 (i-ii). 42 (i-ii). 74 (i-ii). 76. 96. 138 (ii). 140.
IX. Spinning. Weaving	120 (i-iii). 142 (i-iv).
X. Buildings. Roads. Ventilation	20 (i-iv). 25. 87 (i). 107. 137.
XI. Electric heating. Lamps. Stoves	39 (ii-iii). 75 (i-iv). 126.
XII. Combustion furnaces. Fuel. Gas	50. 51 (i-ii). 55 (i-ii).
XIII. Cooling. Drying. Heating. Steam	29. 34 (i-ii). 64 (i-iii). 123 (ii-iii).
XIV. Cutlery. Furniture. Table and toilet articles ...	30. 52 (i-v). 128. 131.
XV. Books and stationery. Filing documents. Games. Ornamenting. Writing.	11. 16. 73. 93. 132 (i-iii). 146 (i-iii).
XVI. Printing. Typewriting	100 (i-iv).
XVII. Containers. Packing	18. 21. 66. 94 (i-ii). 125 (i-iii). 133.
XVIII. Advertising. Coin-freed apparatus. Horology. Measured quantities. Regulating liquids. Shop accessories. Weighing.	3 (i-ii). 27. 106 (v). 116. 123 (i). 139. 143.
XIX. Calculating. Registering	106 (i-iv).
XX. Photography. Scientific instruments	97 (i-iii). 98 (i-ii).
XXI. Excavating and mining. Fires, Fighting. Lifesaving. Subaqueous buildings. Warfare.	9 (i-ii). 47 (i-ii). 68 (i-ii). 77. 85. 92 (i-ii). 119.
XXII. Casting, cutting, and working metals	83 (i-iv).
XXIII. Abrading. Brushing and cleaning. Glass. Hand tools. Stone. Wood.	19. 56. 60. 61 (i-iii). 124. 138 (i). 145 (i-ii).
XXIV. Gearing	80 (i-iv).
XXV. Chains and ropes. Doors, Operating. Hinges. Locks and fastenings.	24. 44. 65 (i-ii). 89 (i-ii). 109.
XXVI. Centrifugal and rotary pumps. Governors. Steam engines. Turbines.	10. 57. 110 (i-iii). 122 (i-v).
XXVII. Internal-combustion, hot-air, and combustion-product engines.	7 (i-vi).
XXVIII. Compressing and conveying gases. Injectors. Pipes. Reciprocating pumps.	8 (i-ii). 71. 99 (i-ii). 102 (i-ii).
XXIX. Gas distribution. Hydraulic apparatus. Valves.	54. 69 (i-iii). 135.
XXX. Conveyors, Lifts. Railways. Railway signals ...	78 (i-v). 104 (i-iii). 105.
XXXI. Cycles. Motor vehicles	79 (i-v). 136 (i-iii).
XXXII. Rail and road vehicles. Springs	103 (ii-vi). 108 (i-iii).
XXXIII. Aircraft. Ships	4. 113 (i-ii). 114. 115.
XXXIV. Bearings. Brakes. Wheels	12 (i-iii). 103 (i). 144 (i-ii).
XXXV. Dynamo-electric machines. Electrical converters and transformers, supply and transmission systems.	35. 38 (ii). 38 (iv).
XXXVI. Electrical conduction, insulation, measurement, and testing. Electrolysis. Galvanic batteries.	36. 37. 38 (i). 41. 53.
XXXVII. Electric switches, switchgear, protective cut-out and motor control systems.	38 (iii). 38 (v).
XXXVIII. Music. Phonographs. Signals and alarms	13. 40 (i-ii). 88 (i-ii). 118 (i-ii).
XXXIX. Telephones	40 (iv).
XL. Arc lamps. Telegraphs and television. Thermionic valves. Wireless.	39 (i). 40 (iii). 40 (v).



ABRIDGMENT CLASS AND INDEX KEY

(Revised Edition, 1927).

Key to the Abridgment Classes and Index Headings under which Inventions are classified in the official publications of the Patent Office.

Vol I. 7s. 6d. (inland); 8s. 1d. (abroad).

Contents :—Lists of Abridgment Classes arranged numerically and alphabetically, Table of Contents of Abridgment Classes, Consolidated List of Index Headings and main cross-references, arranged alphabetically.

Volume II, showing in detail the subdivisions of each Index Heading and the cross-references thereunder, is in course of preparation. It should be noted, however, that the detailed contents of any particular Index Heading can be ascertained from an inspection of the index of the appropriate Class Abridgment Volume for the period 1921-1925 or 1926-30 (if published).

FIFTY YEARS SUBJECT INDEX 1861-1910.

6d. per volume.

A subject index of all published Complete Specifications of the years 1861-1910 classified in 271 volumes corresponding to the series (B) of Illustrated Abridgment Classes. To some extent the headings in the "Fifty Years Subject Index" may be regarded as a compilation of the corresponding headings in the Abridgment volumes, and, so far as this is the case, the Index may be used with the Abridgments. But, generally speaking, the Index headings represent an extended and improved classification of matter, and it may often be found more convenient to use the "Fifty Years Subject Index" with the Specifications, as the contents of the new Index headings will not always be found collected in any one Abridgment Class.

For a continuation of the "Fifty Years Subject Index" the searcher should consult the appropriate Abridgment Volumes for the periods 1909-15, 1916-20, and 1921-25, the subsequent Annual and Quarterly Subject-Matter Indexes, and the Subject-Matter Indexes published weekly in the Official Journal (Patents).



ULTIMHEAT®
VIRTUAL MUSEUM



ULTIMHEAT®
VIRTUAL MUSEUM